

INTERNATIONAL STANDARD

**Radio data system (RDS) – VHF/FM sound broadcasting in the frequency range
from 64,0 MHz to 108,0 MHz –
Part 10: UECP – Universal Encoder Communication Protocol**





THIS PUBLICATION IS COPYRIGHT PROTECTED
Copyright © 2021 IEC, Geneva, Switzerland

All rights reserved. Unless otherwise specified, no part of this publication may be reproduced or utilized in any form or by any means, electronic or mechanical, including photocopying and microfilm, without permission in writing from either IEC or IEC's member National Committee in the country of the requester. If you have any questions about IEC copyright or have an enquiry about obtaining additional rights to this publication, please contact the address below or your local IEC member National Committee for further information.

IEC Central Office
3, rue de Varembe
CH-1211 Geneva 20
Switzerland

Tel.: +41 22 919 02 11
info@iec.ch
www.iec.ch

About the IEC

The International Electrotechnical Commission (IEC) is the leading global organization that prepares and publishes International Standards for all electrical, electronic and related technologies.

About IEC publications

The technical content of IEC publications is kept under constant review by the IEC. Please make sure that you have the latest edition, a corrigendum or an amendment might have been published.

IEC publications search - webstore.iec.ch/advsearchform

The advanced search enables to find IEC publications by a variety of criteria (reference number, text, technical committee, ...). It also gives information on projects, replaced and withdrawn publications.

IEC Just Published - webstore.iec.ch/justpublished

Stay up to date on all new IEC publications. Just Published details all new publications released. Available online and once a month by email.

IEC Customer Service Centre - webstore.iec.ch/csc

If you wish to give us your feedback on this publication or need further assistance, please contact the Customer Service Centre: sales@iec.ch.

IEC online collection - oc.iec.ch

Discover our powerful search engine and read freely all the publications previews. With a subscription you will always have access to up to date content tailored to your needs.

Electropedia - www.electropedia.org

The world's leading online dictionary on electrotechnology, containing more than 22 000 terminological entries in English and French, with equivalent terms in 18 additional languages. Also known as the International Electrotechnical Vocabulary (IEV) online.



IEC 62106-10

Edition 1.0 2021-11

INTERNATIONAL STANDARD

**Radio data system (RDS) – VHF/FM sound broadcasting in the frequency range
from 64,0 MHz to 108,0 MHz –
Part 10: UECP – Universal Encoder Communication Protocol**

INTERNATIONAL
ELECTROTECHNICAL
COMMISSION

ICS 33.060.01; 33.160.20; 33.170

ISBN 978-2-8322-1042-4

Warning! Make sure that you obtained this publication from an authorized distributor.

CONTENTS

FOREWORD.....	6
INTRODUCTION.....	8
1 Scope.....	9
2 Normative references	9
3 Terms, definitions and abbreviated terms	9
3.1 Terms and definitions.....	9
3.2 Abbreviated terms.....	10
4 RDS encoder hardware model	10
5 RDS encoder software model	12
6 Destination addressing method.....	13
6.1 General.....	13
6.2 Site address.....	14
6.3 Encoder address.....	15
7 Transmission modes.....	15
7.1 General.....	15
7.2 Uni-directional mode	15
7.3 Bi-directional mode, requested response	15
7.4 Bi-directional mode, spontaneous response	15
8 Protocol description.....	15
8.1 Data format.....	15
8.2 Data link layer.....	15
8.2.1 General	15
8.2.2 Data-frame	16
8.2.3 Byte-stuffing method.....	19
8.2.4 Message field format	19
8.3 Message codes.....	21
8.3.1 General	21
8.3.2 Remote and configuration commands	21
8.3.3 RDS messages.....	21
8.3.4 Handling of RDS message bits declared "rfu"	21
8.3.5 Status messages	21
8.3.6 Specific messages.....	21
8.4 Description of data handling.....	21
8.5 Group sequence configuration	22
8.5.1 Basic principles used.....	22
8.5.2 Group sequence determination	22
8.5.3 Extended group sequence command	22
8.5.4 Relative priority group sequence command.....	22
8.5.5 Special transmission conditions	22
8.6 Handling of ODA data	23
8.6.1 Using ODAs on data-stream 0	23
8.6.2 Using ODAs on the upper data-streams 1 to 3	23
Annex A (normative) UECP message command repertoire.....	26
A.1 Message command format	26
A.2 Commands for A or B-type groups on data-stream 0	26
A.2.1 PI / MEC 0x01	26

A.2.2	PS / MEC 0x02	27
A.2.3	Long PS / MEC 0x21	28
A.2.4	Data group for PTYI / MEC 0x04	28
A.2.5	TP – TA / MEC 0x03	29
A.2.6	PTY / MEC 0x07	29
A.2.7	PTYN / MEC 0x3E	30
A.2.8	RT / MEC 0x0A	30
A.2.9	AF / MEC 0x13	33
A.2.10	EON-AF / MEC 0x14	34
A.2.11	ECC and other slow label settings / MEC 0x1A	35
A.2.12	Linkage information / MEC 0x2E	36
A.2.13	Free-format data in type A or B group / MEC 0x24	36
A.3	Commands for ODAs on data-stream 0	37
A.3.1	Group type 3A ODA configuration and short message command / MEC 0x40	37
A.3.2	ODA assignment group usage sequence signalling / MEC 0x41	39
A.3.3	ODA relative priority group sequence / MEC 0x43	40
A.3.4	ODA data group repetitions and burst mode / MEC 0x44	40
A.3.5	ODA "spinning wheel" timing control / MEC 0x45	41
A.3.6	ODA data / MEC 0x46	42
A.3.7	ODA data command access right / MEC 0x47	44
A.4	Commands for clock setting and control for data-stream 0	45
A.4.1	Real time clock for CT / MEC 0x0D	45
A.4.2	Real time clock correction for CT / MEC 0x09	46
A.4.3	CT on-off command / MEC 0x19	46
A.5	Commands for RDS signal alignment and control on data-stream 0	47
A.5.1	RDS on-off command data-stream 0 / MEC 0x1E	47
A.5.2	RDS phase for subcarrier 0 / MEC 0x22	47
A.5.3	RDS level for subcarrier 0 / MEC 0x0E	48
A.6	Message name commands control and set-up commands on data-stream 0	49
A.6.1	Site address / MEC 0x23	49
A.6.2	Encoder address / MEC 0x27	49
A.6.3	Make PSN list / MEC 0x28	50
A.6.4	PSN enable-disable / MEC 0x0B	50
A.6.5	EON elements enable-disable / MEC 0x3F	51
A.6.6	Communication mode / MEC 0x2C	52
A.6.7	TA control / MEC 0x2A	53
A.6.8	EON-TA control / MEC 0x15	53
A.6.9	Reference input select / MEC 0x1D	54
A.6.10	Data set select / MEC 0x1C	54
A.6.11	Group sequence determination for data-stream 0 / MEC 0x16	54
A.6.12	Extended group sequence for data-stream 0 / MEC 0x38	55
A.6.13	Group variant code sequence for data-stream 0 / MEC 0x29	57
A.6.14	Encoder access right / MEC: 0x3A	58
A.6.15	Communications port configuration – Mode / MEC 0x3B	59
A.6.16	Communications port configuration – Speed / MEC 0x3C	60
A.6.17	Communications port configuration – Timeout / MEC 0x3D	62
A.6.18	Message acknowledgment / MEC 0x18	63
A.6.19	Request message / MEC 0x17	64

A.7	Manufacturers' and transmission operators' specific command / MEC 0x2D	65
A.8	Commands for the C-type groups used on data-streams 1 to 3	66
A.8.1	ODA-AID channel assignment for AS group type C (Alternative 1)/MEC 0x50	66
A.8.2	ODA-AID channel assignment for AS group type C (Alternative 2) / MEC 0x51	68
A.8.3	Relative priority group sequence / MEC 0x53	71
A.8.4	Burst mode control for ODA group type C / MEC 0x54	71
A.8.5	RFT file data transfer (Alternative 2)/MEC 0x55.....	72
A.8.6	ODA data group command / MEC 0x56.....	73
A.8.7	RFT file data transfer and associated data for the assignment group(s) variants 0 and 1 (Alternative 1) / MEC 0x57.....	75
A.8.8	File associated data for AS group variants 2 to 7 (Alternative 1)/MEC 0x58	76
A.8.9	Define in the RFT a file sequence for the AID/MEC 0x59	78
A.8.10	Define the group sequence / MEC 0x61	79
A.8.11	Extended group sequence for group type C/MEC 0x83	80
A.8.12	Upper data-stream level / MEC 0xE0	82
A.8.13	Upper data-streams on – off/MEC 0xE1	82
Annex B (normative)	UECP transmission over IP networks	84
Annex C (informative)	Transport of UECP data within DVB-S radio.....	85
Annex D (informative)	Manufacturer and transmission operator command code registration	86
Annex E (informative)	Listing of Message Element Codes.....	87
Annex F (informative)	Special optional ODA transmission mode on RDS data-stream 0 with group type A or B	89
F.1	"Burst mode" transmission	89
F.2	"Spinning wheel" mode transmission.....	89
Annex G (normative)	Message Element Codes kept for backwards compatibility on data-stream 0	90
G.1	General.....	90
G.2	ODA data group/MEC 0x42	90
G.3	EWS / MEC 0x2B.....	91
G.4	TDC/MEC 0x26.....	92
G.5	TMC / MEC 0x30	93
G.6	DAB Dynamic label message – DL/MEC 0xAA	93
G.7	DAB Dynamic label command/MEC 0x48	94
Annex H (informative)	Example for defining the group sequence for data-stream 0 including ODA groups	96
Annex I (informative)	Example of how to send a logo with two different resolutions using RFT.....	97
I.1	Send files to the encoder	97
I.1.1	General	97
I.1.2	Alternative 1: using MECs 0x50 and 0x57	97
I.1.3	Alternative 2: using MECs 0x51 and 0x55.....	98
I.2	Data-stream number setting.....	100
I.3	File sequence setting.....	100
Bibliography	101

Figure 1 – RDS encoder hardware model..... 11

Figure 2 – RDS encoder software model..... 13

Figure 3 – Fictitious example of site addressing..... 14

Figure 4 – UECP data-frame format 16

Figure 5 – UECP data frame with the CRC-16 for example 1 being 0x25F4 18

Figure 6 – UECP data frame with the CRC-16 for example 2 being 0x800C 19

Figure A.1 – Message transmission cycle diagram 32

Figure F.1 – "Spinning wheel" mode – one minute transmission cycle that starts with a
4A group..... 89

Table 1 – UECP data-frame description 16

Table 2 – Byte-stuffing method 19

Table 3 – Message structure..... 20

Table 4 – Data set number..... 20

Table 5 – Programme Service Number..... 21

Table A.1 – Message command format 26

INTERNATIONAL ELECTROTECHNICAL COMMISSION

RADIO DATA SYSTEM (RDS) – VHF/FM SOUND BROADCASTING IN THE FREQUENCY RANGE FROM 64,0 MHz TO 108,0 MHz –

Part 10: UECP – Universal Encoder Communication Protocol

FOREWORD

- 1) The International Electrotechnical Commission (IEC) is a worldwide organization for standardization comprising all national electrotechnical committees (IEC National Committees). The object of IEC is to promote international co-operation on all questions concerning standardization in the electrical and electronic fields. To this end and in addition to other activities, IEC publishes International Standards, Technical Specifications, Technical Reports, Publicly Available Specifications (PAS) and Guides (hereafter referred to as "IEC Publication(s)"). Their preparation is entrusted to technical committees; any IEC National Committee interested in the subject dealt with may participate in this preparatory work. International, governmental and non-governmental organizations liaising with the IEC also participate in this preparation. IEC collaborates closely with the International Organization for Standardization (ISO) in accordance with conditions determined by agreement between the two organizations.
- 2) The formal decisions or agreements of IEC on technical matters express, as nearly as possible, an international consensus of opinion on the relevant subjects since each technical committee has representation from all interested IEC National Committees.
- 3) IEC Publications have the form of recommendations for international use and are accepted by IEC National Committees in that sense. While all reasonable efforts are made to ensure that the technical content of IEC Publications is accurate, IEC cannot be held responsible for the way in which they are used or for any misinterpretation by any end user.
- 4) In order to promote international uniformity, IEC National Committees undertake to apply IEC Publications transparently to the maximum extent possible in their national and regional publications. Any divergence between any IEC Publication and the corresponding national or regional publication shall be clearly indicated in the latter.
- 5) IEC itself does not provide any attestation of conformity. Independent certification bodies provide conformity assessment services and, in some areas, access to IEC marks of conformity. IEC is not responsible for any services carried out by independent certification bodies.
- 6) All users should ensure that they have the latest edition of this publication.
- 7) No liability shall attach to IEC or its directors, employees, servants or agents including individual experts and members of its technical committees and IEC National Committees for any personal injury, property damage or other damage of any nature whatsoever, whether direct or indirect, or for costs (including legal fees) and expenses arising out of the publication, use of, or reliance upon, this IEC Publication or any other IEC Publications.
- 8) Attention is drawn to the Normative references cited in this publication. Use of the referenced publications is indispensable for the correct application of this publication.
- 9) Attention is drawn to the possibility that some of the elements of this IEC Publication may be the subject of patent rights. IEC shall not be held responsible for identifying any or all such patent rights.

International Standard IEC 62106-10 has been prepared by technical area 1: Terminals for audio, video and data services and content, of IEC technical committee 100: Audio, video and multimedia systems and equipment.

This first edition, together with IEC 62106-1, IEC 62106-2, IEC 62106-3, IEC 62106-4, IEC 62106-5, IEC 62106-6 and IEC 62106-9, cancels and replaces IEC 62106:2015, and constitutes a technical revision.

This edition includes the following significant technical changes with respect to IEC 62106:2015:

- The Universal Encoder Communication protocol UECP adapted to support optional RDS2 is new.
- The section dealing with legacy RDS using data-stream 0 only is a transcription of an RDS Forum technical specification which was initially developed by the EBU and which was already in its 7th version [1]. Full backwards compatibility with previous versions was maintained, but RDS features no longer specified in IEC 62106-2 were deleted.

The text of this International Standard is based on the following documents:

Draft	Report on voting
100/3643/FDIS	100/3688/RVD

Full information on the voting for its approval can be found in the report on voting indicated in the above table.

The language used for the development of this International Standard is English.

This document was drafted in accordance with ISO/IEC Directives, Part 2, and developed in accordance with ISO/IEC Directives, Part 1 and ISO/IEC Directives, IEC Supplement, available at www.iec.ch/members_experts/refdocs. The main document types developed by IEC are described in greater detail at www.iec.ch/standardsdev/publications.

A list of all parts in the IEC 62106 series, published under the general title *Radio data system (RDS) – VHF/FM sound broadcasting in the frequency range from 64,0 MHz to 108,0 MHz*, can be found on the IEC website.

The committee has decided that the contents of this document will remain unchanged until the stability date indicated on the IEC website under webstore.iec.ch in the data related to the specific document. At this date, the document will be

- reconfirmed,
- withdrawn,
- replaced by a revised edition, or
- amended.

INTRODUCTION

Since the mid-1980s a fascinating development has taken place. Most of the multimedia applications and standards have been created or redefined significantly. Hardware has become extremely powerful with dedicated software and middleware. In the mid-1980s, Internet as well as its protocols did not exist. Navigation systems became affordable in the late 1990s, and a full range of attractive smartphones now exist. The computing power of all these new products is comparable with that of the mainframe installations in that era.

Listener expectations have grown faster than the technology. Visual experience is now very important, like the Internet look and feel. Scrolling text or delivering just audio is nowadays perceived as insufficient for FM radio, specifically for smartphone users. New types of radio receivers with added value features are therefore required. RDS has so far proven to be very successful.

FM radio with RDS is an analogue-digital hybrid system, which is still a valid data transmission technology and only the applications need adaptation. Now the time has come to solve the only disadvantage, the lack of sufficient data capacity. With RDS2, the need to increase the data capacity can be fulfilled.

RDS was introduced in the early 1980s. During the introductory phase in Europe, the car industry became very involved and that was the start of an extremely successful roll-out. Shortly afterwards, RDS (RBDS) was launched in the USA [2, 3, 4, 5, 6].¹

The RDS Forum has investigated a solution to the issue of limited data capacity. For RDS2, both sidebands around the RDS 57 kHz subcarrier can be repeated a few times, up to three, centred on additional subcarriers higher up in the FM multiplex still remaining compatible with the ITU Recommendations.

The core elements of RDS2 are the additional subcarriers, which will enable a significant increase of RDS data capacity to be achieved, and then only new additional data applications will have to be created, using the RDS-ODA feature, which has been part of the RDS standard IEC 62106 for many years.

In order to update IEC 62106:2015 to the specifications of RDS2, IEC 62106 has been restructured as follows:

Part 1: Modulation characteristics and baseband coding

Part 2: RDS message format, coding and definition of RDS features

Part 3: Usage and registration of Open Data Applications ODAs

Part 4: Registered code tables

Part 5: Marking of RDS and RDS2 devices

Part 6: Compilation of technical specifications for Open Data Applications in the public domain

Part 9: RBDS – RDS variant used in North America

Part 10: Universal Encoder Communication Protocol UECP

NOTE 1 The Part numbers 7 and 8 will not be used.

The original specifications of the RDS system have been maintained and the extra functionalities of RDS2 have been added.

Obsolete or unused functions from the original RDS standard have been deleted.

¹ Numbers in square brackets refer to the Bibliography.

RADIO DATA SYSTEM (RDS) – VHF/FM SOUND BROADCASTING IN THE FREQUENCY RANGE FROM 64,0 MHz TO 108,0 MHz –

Part 10: UECP – Universal Encoder Communication Protocol

1 Scope

This part of IEC 62106 describes the Universal Encoder Communication Protocol – UECP. The UECP has as its primary objectives to satisfy the need for harmonized RDS encoder communication protocols and to facilitate the interworking of various RDS systems components, such as RDS servers, data bridges and encoders, regardless of the supplier. Furthermore, a harmonised network environment and encoder model is being maintained to facilitate the interchange of component parts of RDS network systems. These harmonized models and a universal layered protocol are specified, based on the ISO/OSI recommendation. The UECP encompasses all current RDS features including any new developments using the ODA protocol.

2 Normative references

The following documents are referred to in the text in such a way that some or all of their content constitutes requirements of this document. For dated references, only the edition cited applies. For undated references, the latest edition of the referenced document (including any amendments) applies.

IEC 62106-1, *Radio data system (RDS) – VHF/FM sound broadcasting in the frequency range from 64,0 MHz to 108,0 MHz – Part 1: Modulation characteristics and baseband coding*

IEC 62106-2:2021, *Radio data system (RDS) – VHF/FM sound broadcasting in the frequency range from 64,0 MHz to 108,0 MHz – Part 2: Message format: Coding and definition of RDS features*

IEC 62106-4, *Radio data system (RDS) – VHF/FM sound broadcasting in the frequency range from 64,0 MHz to 108,0 MHz – Part 4: Registered code tables*

ETSI EN 300 401, *Radio Broadcasting Systems; Digital Audio Broadcasting (DAB) to mobile, portable and fixed receivers*

ETSI TS 101 756, *Digital Audio Broadcasting (DAB); Registered Tables*

ETSI TS 102 980, *Digital Audio Broadcasting (DAB); Dynamic Label Plus (DL Plus); Application specification*

3 Terms, definitions and abbreviated terms

3.1 Terms and definitions

For the purposes of this document, the terms, definitions and abbreviated terms of IEC 62106-1, of IEC 62106-2 and the following apply.

ISO and IEC maintain terminological databases for use in standardization at the following addresses:

- IEC Electropedia: available at <http://www.electropedia.org/>
- ISO Online browsing platform: available at <http://www.iso.org/obp>

3.2 Abbreviated terms

ADD	Destination address bytes (2 bytes)
AS	Assignment signalling (assign channel/pipe to AID) for RDS2
CRC-16	Cyclic Redundancy Check (2 bytes)
DAB	Digital Audio Broadcasting
DL	Dynamic Label (DAB)
DSN	Data Set Number
DVB-S	Digital Video Broadcasting via Satellite
ID	Identification
IP	Internet Protocol
GS	Group sequence
MEC	Message Element Code
MED	Message Element Data
MEL	Message Element data Length
MFL	Message Field Length
MSG	Message bytes
PSN	Programme Service Number
RFT	RDS2 File Transfer protocol
SQC	Sequence counter byte
STA	Start byte
STP	Stop byte
TCP	Transmission Control Protocol used on the Internet
UDP	User Datagram Protocol used on the Internet
UECP	Universal Encoder Communication Protocol

4 RDS encoder hardware model

A simplified model of an RDS encoder with data-stream 0 and three optional upper data-streams 1 – 3 is shown in Figure 1. The model does not include such obvious or necessary components as a power supply or control panel, but includes the blocks necessary to understand and develop the protocol itself.

These blocks are:

- Processor – the central processing unit of the encoder, usually a micro-processor, with access to input and output devices, the real-time clock, and memory.
- Memory – comprises ROM and RAM necessary for the operating software of the encoder, and appropriate RAM, NVRAM, and ROM for stored data.
- Real time clock – maintains the current time of day and calendar date. Used to generate type 4A groups (CT).

- Communication interface – UECP data using this specification is received from an RDS data server of the broadcaster or a transmission operator and transmitted using the serial communications interface. Alternatively, an IP interface may be used. The appropriate IP transmission methods are described in Annex B.
- RDS modulator – produces the RDS bi-phase signal, in accordance with IEC 62106-1.
- 57 kHz subcarrier – frequency and phase locked to the third harmonic of the selected 19 kHz pilot-tone reference source.
- 66,5 kHz subcarrier – frequency and phase locked to the third harmonic of the selected 19 kHz pilot-tone reference source and used to generate data-stream 1.
- 71,25 kHz subcarrier – frequency and phase locked to the third harmonic of the selected 19 kHz pilot-tone reference source and used to generate data-stream 2.
- 76 kHz subcarrier – frequency and phase locked to the third harmonic of the selected 19 kHz pilot-tone reference source and used to generate data-stream 3.
- Reference selector (optional): selects one source of the 19 kHz pilot-tone reference signal, out of a maximum of six, to lock to the internal 57 kHz oscillator. Each 19 kHz reference source corresponds to a specific level and phase adjustment of the produced output signal. When a specific reference source is selected via the Reference selector, the corresponding level and phase values are taken from a "reference entry table". This table comprises the following parameters: RDS output level for each of the data-streams (see IEC 62106-1).
- RDS subcarrier 0 phase relative to the pilot (see IEC 62106-1 for conditions to be met).
- Level and phase control: the level of each subcarrier and phase of subcarrier 0 shall be adjusted by the processor under the appropriate commands (see Annex A). The phase of subcarriers 1, 2, and 3 shall be phase locked to subcarrier 0 (see IEC 62106-1). The output level shall be set in the range 0 mV to 8 191 mV, and the phase in the range between 0° and 360° to lock to the internal 57 kHz oscillator. Level and phase of the RDS signal may depend of the 19 kHz pilot-tone reference signal. As up to six reference inputs may be used, level and phase are set on the "reference table entry", as mentioned under the item "Reference selector" above.

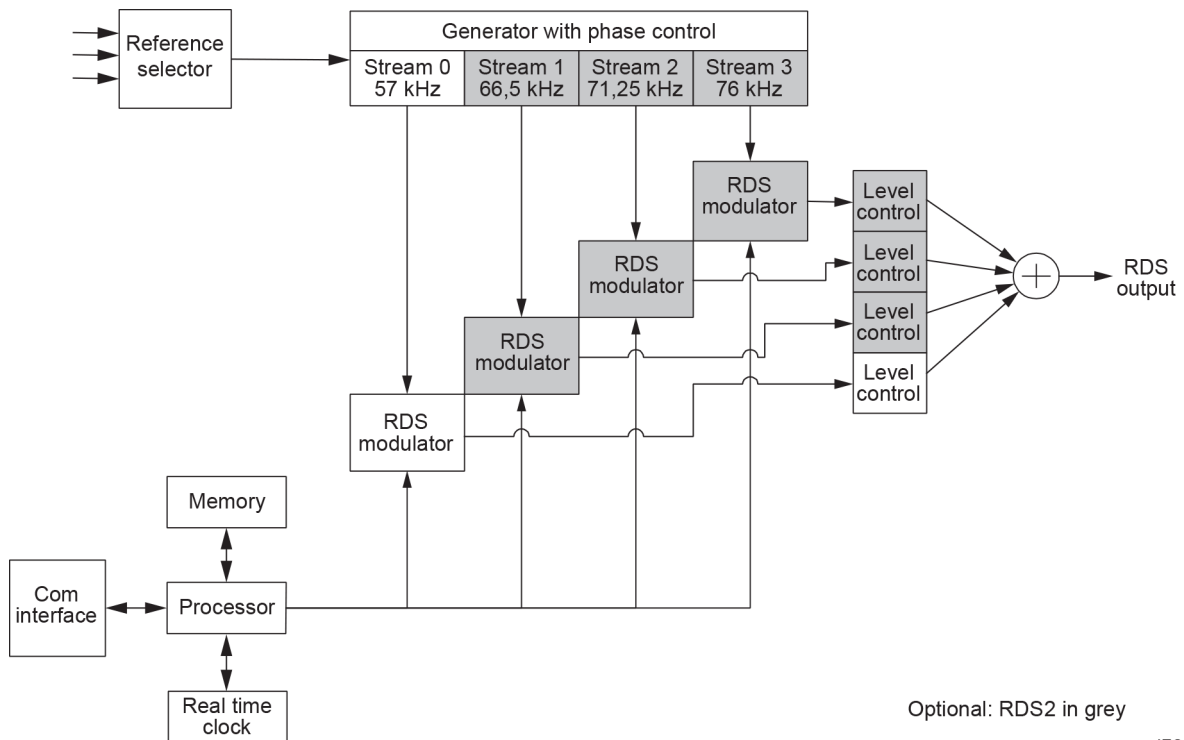

Figure 1 – RDS encoder hardware model

5 RDS encoder software model

The encoder in accordance with the addressing method described in Clause 6 accepts messages, which are detailed in Clause 8. Applicability is further determined by optional fields within the message itself. This permits addressing of the structures shown in Figure 2:

- **Data sets:** an encoder will have one or more data sets identified by a unique DSN, each of which results in a particular RDS output. Each data set may refer to many programme services using the RDS-EON feature. Only one data set is responsible at any one time for the encoder's output and is known as the current data set. Data sets are addressed by the protocol as described in Clause 8.
- **Programme services:** all programme services are identified by a unique Programme Service Number PSN which is used to label data within RDS networks. In a network providing the EON feature, data for several programme services will be sent to an encoder, which can then identify that the data refers to one or more of the data sets and elements within the data sets used by that encoder. Programme services are addressed using the PSN by the protocol as described in Clause 8. There is a specific memory area in each data set for each programme service.
- **Buffers:** some information is buffered, for example ODAs, EWS and other free format groups. This means that the received information is placed in a queue awaiting transmission. It is possible to configure a buffer for cyclic transmission.

On the upper data-streams for RDS2, only C-type groups are used. For A and B type groups on the upper data-streams, C-type tunneling shall be used (see IEC 62106-2).

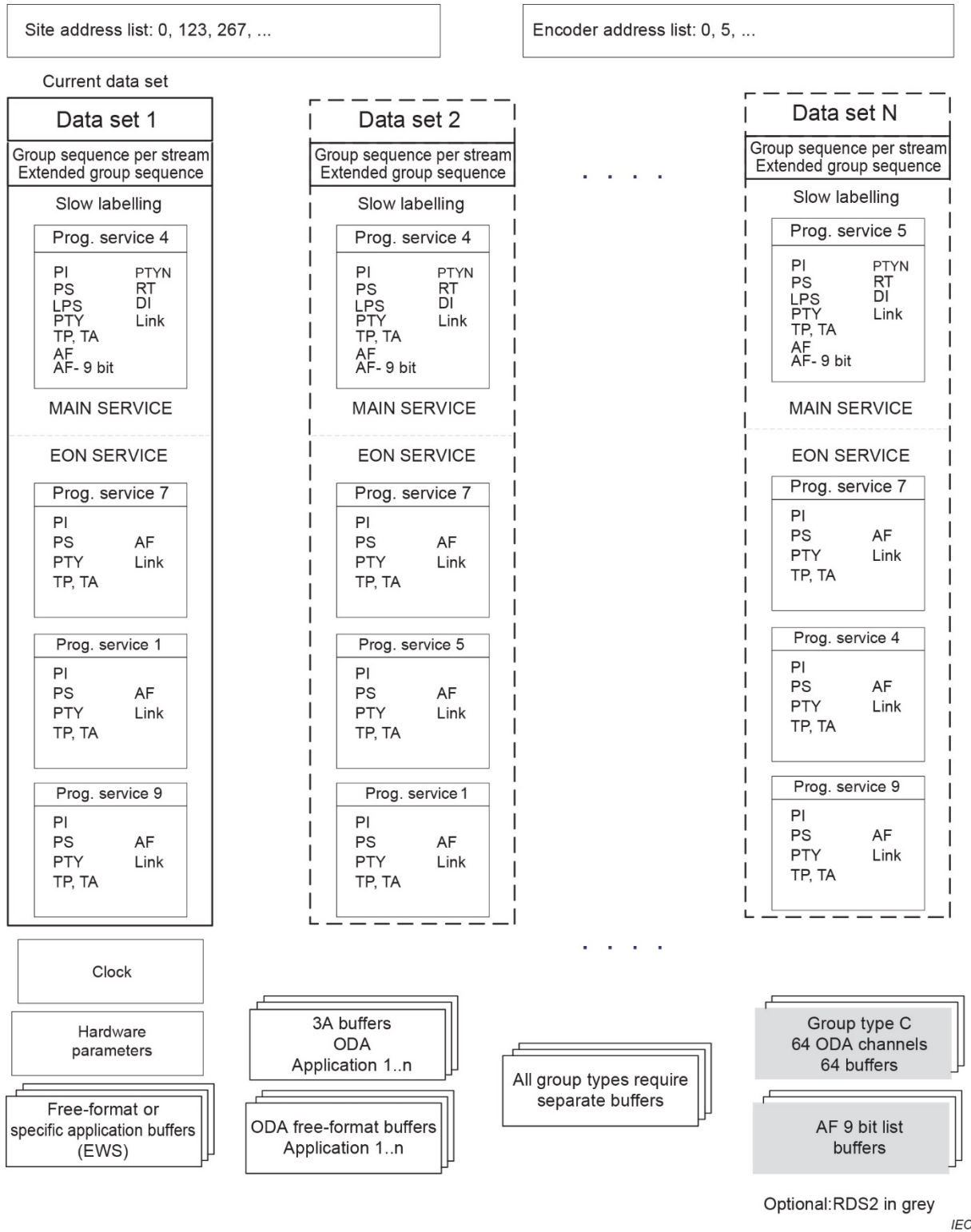

Figure 2 – RDS encoder software model

6 Destination addressing method

6.1 General

Communication to RDS encoders needs to be capable of many levels of addressing: to all encoders, to specific sets of encoders, or to a particular device. This may be accomplished by unique physical connections or by a suitable logical addressing method.

It is expected that many messages will be sent to all encoders. Thus, the global number of "0" is defined for both the site and encoder addresses. Messages bearing the global site address are deemed to be acceptable at all sites in the system. Messages bearing the global encoder address are deemed to be acceptable at all encoders at sites specified by the accompanying site address.

An encoder will have two destination address lists, one of acceptable site addresses and the other of acceptable encoder addresses; see Figure 2. The site address list includes "0" (the global site address), the unique site address and any additional site group addresses. The encoder address list includes "0" (the global encoder address), the unique encoder address and any additional encoder group addresses.

A message is acceptable to a particular encoder only if the site address is contained within its site address list and the encoder address is contained within its encoder address list.

The site and encoder addresses should be thought of as being entirely physical and are used only to address a certain "box" at a certain location; the functionality of the "box" is irrelevant in this context.

6.2 Site address

In defining an environmental model for the UECP the following assumptions are made:

- The data-stream will feed one or more transmitter sites. Each site will have a unique address, known as the site address (a number in the range 1 to 1 023). All encoders at a particular transmitter site share the same site address.
- An encoder will possess one or more site addresses. One of these shall be unique to the particular physical site location. Additional site addresses are permitted for a particular area, region, or country.

To clarify this concept, an example is given in Figure 3.

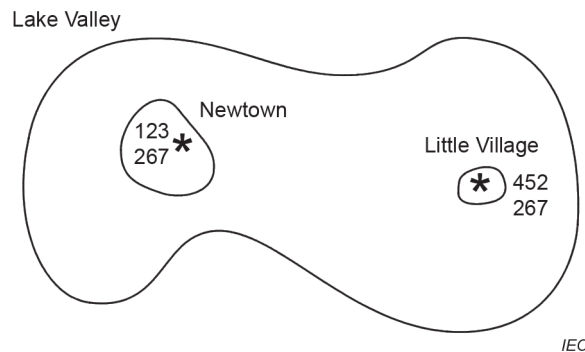

Figure 3 – Fictitious example of site addressing

All encoders at the NEWTOWN site have the unique site address "123". Other encoders in the system are not permitted to use this address. Encoders at the NEWTOWN site also have the site address "267", which is allocated to all encoders in the LAKE VALLEY area. Messages arriving at the NEWTOWN site with either of these two site addresses will be accepted. Messages arriving at the LITTLE VILLAGE site (address "452"), also in the LAKE VALLEY area, will not be accepted if they carry the NEWTOWN site address, but will be accepted if they carry either the LITTLE VILLAGE or the LAKE VALLEY site addresses.

6.3 Encoder address

Several RDS encoders are installed at each transmitter site, serving a number of programme services. Backup equipment is sometimes provided, sometimes not. A single backup encoder can even be provided for several programme services. Whatever the situation may be, each encoder at the site needs to be individually addressable. A second level of addressing is therefore introduced, the encoder address (a number in a range 1 to 63).

An encoder will possess one or more encoder addresses. One shall be unique to the encoder at that site. Additional encoder addresses may be assigned in accordance with the encoder's usage or manufacture. However, the site and encoder addresses are not intended to specify a particular radio service.

7 Transmission modes

7.1 General

The UECP protocol is designed to operate using serial communication.

The communication is always the same, regardless of which mode will be used. Whether the transmission mode is then taken as I2C, RS232, USB, UDP/TCP (see Annex B), or DVB-S (see Annex C), the transmitting device itself does not change the UECP protocol (see Clause 8).

7.2 Uni-directional mode

This mode is used on one-way communication links. Data is transmitted to one, a group, or all encoders. Response from the encoder is not possible.

7.3 Bi-directional mode, requested response

This mode uses a two-way communication link to transmit data to one, a group or all encoders. It allows the RDS server to request data, status, and error report from encoders.

7.4 Bi-directional mode, spontaneous response

A two-way communication link allows UECP software to transmit data to encoders and request data from encoders. Encoders are also able to spontaneously generate status and error messages. Such messages, their content and application are described in Annex A (MEC 0x18).

8 Protocol description

8.1 Data format

The data is transmitted byte by byte in asynchronous mode. In short it is: Start byte STA; then stuffed data bytes (as described in 8.2.3); then terminated by the end Stop byte STP.

8.2 Data link layer

8.2.1 General

Update data comprises a stream of data-frames. A frame comprises a series of bytes, delimited by the two reserved bytes, STA (Start) and STP (Stop), which mark the beginning and end of the frame. Each frame contains a destination address (ADD), defining the set of encoders to which the message is being sent. A sequence counter (SQC) labels each separate record. The message itself is preceded by the MFL byte defining the message field length and it is followed by the two CRC-16 checkword bytes.

The Start and Stop bytes are uniquely defined and may not occur in any other field of a frame. In order to prevent this, a frame is byte-stuffed prior to transmission. Byte-stuffing transforms an occurrence of a reserved byte into two bytes (see 8.2.3). The reverse process is applied at reception, where byte-stuffed frames are converted prior to frame processing. Thus, although the Start and Stop bytes are reserved, messages may freely use bytes with any value. In cases where reserved byte values are present in the message, the transmitted message length will be increased. However, the message field length MFL is always defined in its unstuffed, shortest, state.

8.2.2 Data-frame

8.2.2.1 Data-frame format

Each data-frame has the format shown in Figure 4.

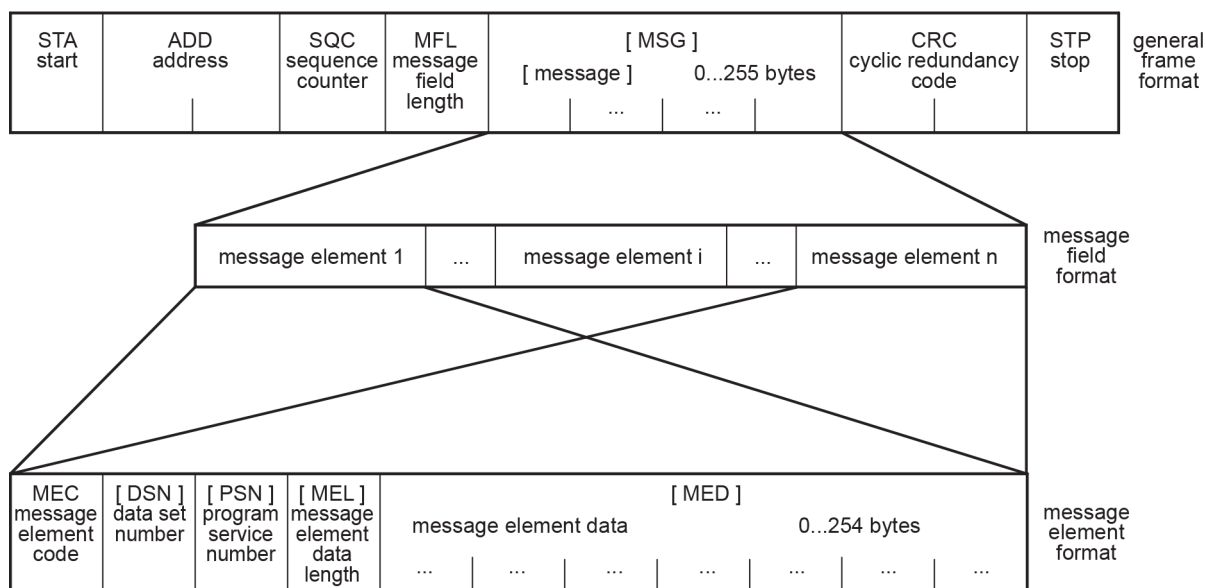

[] Fields in brackets are optional. Inclusion is inherently defined by message element code

IEC

Figure 4 – UECP data-frame format

Each data-frame has the format shown in Table 1.

Table 1 – UECP data-frame description

Field description	Descriptor	Field length
Start	STA	1 byte
Destination address	ADD	2 bytes
Sequence counter	SQC	1 byte
Message field length	MFL	1 byte
[Message]	[MSG]	0...255 bytes
CRC-16 checkword	CRC	2 bytes
Stop	STP	1 byte

The symbols [] indicate that this field is optional. When not included, the message field will be set to zero. Such a record may be used to indicate an idle line (not being used, but ready).

Frames are built in accordance with this structure, and then byte-stuffed prior to transmission. Byte-stuffing removes any occurrences of reserved bytes (0xFE for STA and 0xFF for STP) within the fields "ADD – Destination Address" to "CRC – Cyclic Redundancy Check" inclusively.

The message field length MFL is only one byte, thus limiting the length of the message to 255 bytes.

8.2.2.2 Start (STA)

A data record starts with the start byte (0xFE). This byte will not occur at any other point in a transmitted sequence (after byte-stuffing).

8.2.2.3 Address (ADD)

The address field comprises two elements, these are:

Site address	10 bits (most significant)
Encoder address	6 bits (least significant)

For a message to be acceptable to a particular encoder, both the site address and the encoder address shall be contained within the respective address lists of the encoder.

8.2.2.4 Site address

The site address defines the site, or group of sites to which this record is being sent.

0x000	=	All sites
0x001 – 0x3FF	=	Specific site or group of sites, as selected by encoder operator

Each encoder with duplex mode will acknowledge a series of site address codes. One shall be unique, i.e. common to all encoders at a particular location. Another may be common to all encoders in a certain area, and so on.

8.2.2.5 Encoder address

The encoder address defines to which encoder(s) at a particular site this record is being sent.

0x00	=	All encoders at the site
0x01 – 0x3F	=	Specific encoder or group of encoders, as selected by the encoder operator.

Each encoder with duplex mode will acknowledge a series of site address codes. One shall be unique, i.e. common to all encoders at a particular location. Another may be common to all encoders in a certain area, and so on.

8.2.2.6 Sequence counter (SQC)

The purpose of the Sequence counter in the UECP data-frame is to help data providers to improve their communication link with encoders. An encoder may identify less-than-perfect data communication between the RDS distribution server and the encoder, regardless of whether either a unidirectional protocol or bi-directional protocol is employed. In a perfect connection environment, UECP frames will arrive without any 'gaps' in the Sequence counter, each frame incremented by '1' from the preceding frame. Hence, when gaps are noted at the encoder by missing Sequence counter values, this will indicate that improvements should be made to the distribution system. When gaps are identified, frames with a non-consecutive SQC shall be accepted by the encoder. Additionally, where there is a one-to-one relationship between a server and an encoder and a bi-directional communication protocol is used, a possibility exists for the encoder with MEC 0x18 to signal a missing frame so that the server can thus resend it.

Broadcasters/Service providers shall either ensure that the Sequence counter value increments by 'one' from 1...255 and complete the sequence before restarting, or that optionally they send all UECF frames with the sequence counter set to '0', which will disable the sequence counter functionality completely.

8.2.2.7 Message field length (MFL)

This single byte informs the encoder of the number of bytes in the message field (0..255). This value is defined as that prior to byte-stuffing applied.

8.2.2.8 Message (MSG)

The message comprises 0 to 255 bytes of data. These bytes may freely take any value in the range 0x00 – 0xFF. Byte stuffing is applied afterwards.

8.2.2.9 Cyclic redundancy check (CRC-16)

The checkword field consists of two bytes (prior to byte-stuffing), which represent the result of a 16-bit cyclic redundancy check (CRC-16) calculation.

The divisor polynomial used to generate the CRC-16 is the ITU-T/CCITT polynomial

$$x^{16} + x^{12} + x^5 + 1$$

The CRC-16 calculation starts with the most significant bit of the field immediately following the start character and ends with the least significant bit of the character immediately preceding the first CRC-16 character, i.e. it ends with the least significant bit of the last byte of the message field. The CRC-16 is initialized to a value of 0xFFFF, and the two check bytes are formed from the inverse of the result. The eight most significant bits are represented by the first check field byte, and the eight least significant bits are represented by the second check field byte (see IEC 62106-2 for more detail regarding the CRC-16 calculation).

EXAMPLE 1:

MEC 0x02 is used to send a PS name with

„PS_RDS_ for DSN 3 (0x03) and PSN 6 (0x06) to encoder 18 (0x12) on site 837 (0x345).

MEC 0x02 is <02><03><06><20><50><53><20><52><44><53><20>

The SQC byte is set to 0x01.

The calculation of the CRC-16 based on this data is illustrated in Figure 5.

STA	ADD	SQC	MFL	MEC	DSN	PSN	PS character #1	PS character #2	PS character #3	PS character #4	PS character #5	PS character #6	PS character #7	PS character #8	CRC	STO	
FE	D1	52	01	0B	02	03	06	20	50	53	20	52	44	53	20	25F4	FF

Encoder = 0x12	Length = 11 bytes	Define a PS text	<Space>	P	S	<Space>	R	D	S	<Space>
Site = 0x345										

IEC

Figure 5 – UECF data frame with the CRC-16 for example 1 being 0x25F4

The corresponding UECF data-frame with the CRC-16 is

<FE><D1><52><01><0B><02><03><06><20><50><53><20><52><44><53><20><25><F4><FF>

EXAMPLE 2:

MEC 0x02 is used to send a PS name with

„PS_RDS_ for DSN 3 (0x03) and PSN 6 (0x06) to encoder 63 (0x3F) on site 1022 (0x3FE).

MEC 0x02 is <02><03><06><20><50><53><20><52><44><53><20>

The SQC byte is set to 0x00.

The calculation of the CRC-16 based on this data is illustrated in Figure 6.

NOTE The byte stuffing method is applied on ADD.

STA	ADD	SQC	MFL	MEC	DSN	PSN	PS character #1	PS character #2	PS character #3	PS character #4	PS character #5	PS character #6	PS character #7	PS character #8	CRC	STO
FE	FD02 BF	00	0B	02	03	06	20	50	53	20	52	44	53	20	800C	FF

Encoder = 0x3F	Length = 11 bytes	Define a PS text	<Space>	P	S	<Space>	R	D	S	<Space>
Site = 0x3FE										

IEC

Figure 6 – UECP data frame with the CRC-16 for example 2 being 0x800C

The corresponding UECP data-frame with the CRC-16 is

<FE><FD><02><BF><00><0B><02><03><06><20><50><53><20><52><44><53><20><80><0C><FF>

8.2.2.10 Stop (STP)

A data record ends with the stop byte (0xFF). This byte will not occur at any other point in a transmitted sequence (after byte-stuffing).

8.2.3 Byte-stuffing method

The technique of byte-stuffing allows a byte-oriented protocol, such as this one, to preserve certain unique values for framing purposes, and yet allow conveyed messages to utilize the full byte range (0x00 to 0xFF). This is achieved by trapping reserved bytes in illegal fields and transforming them into legal byte pairs.

Byte values 0xFD, 0xFE, and 0xFF are trapped in the fields "Address" to "Cyclic Redundancy Check" and transformed into a pair of bytes as shown in Table 2.

Table 2 – Byte-stuffing method

Byte		Resultant byte pair
0xFD	transformed into	0xFD 00
0xFE	transformed into	0xFD 01
0xFF	transformed into	0xFD 02

Thus, the reserved bytes (0xFE and 0xFF) will never occur within these fields in a transmitted record and will only occur within the start and stop fields.

When a message is received, the reverse technique is used to transform two-byte sequences (always starting with 0xFD), into single bytes prior to the record being processed.

8.2.4 Message field format

8.2.4.1 Message structure

The message field, if non-zero in length consists of one or more message elements. Each message element has the structure as shown in Table 3.

Table 3 – Message structure

Field description	Descriptor	Field length
Message element code	MEC	1 byte
[Data set number]	[DSN]	0...1 byte
[Programme service number]	[PSN]	0...1 byte
[Message element data length]	[MEL]	0...1 byte
[Message element data]	[MED]	0...254 bytes
The symbols [] indicate that this field is optional. They are used, as required by the specific command, see Annex A.		

Several message elements may be packed together into one message field, subject to a maximum message field length of 255 bytes, as defined in 8.2.2.1. An individual message element shall not be split between different message fields.

The complete message field may be represented as follows:

[MEC,[DSN],[PSN],[MEL],[MED]], [MEC,[DSN],[PSN],[MEL],[MED]], ...

Fields and whole message elements shown in square brackets are optional. Message elements may be concatenated freely, subject to a maximum message field length of 255 bytes.

The maximum available length for a message element is 255 bytes. This inherently limits the message element data to 254 bytes. If the optional fields "Data Set Number", "Programme Service Number", and/or "Message element data length" are used, further reduction to the maximum message element data length will occur. For example, if all optional fields are employed, the maximum element data length will be 251 bytes.

8.2.4.2 Message element code (MEC)

The Message element code identifies a particular message, as defined in Annex A. The Message element code is within the range 0x01..0xFD. The codes 0x00, 0xFE and 0xFF are not permitted for defining a MEC, as they are used in this specification with a special meaning, always defined in the conventions for a specific command. A listing of all codes for MECs used is given in Annex E.

8.2.4.3 Data set number (DSN)

The data set number (DSN) permits a message to be targeted to the following within an encoder:

- a specific data set,
- the current data set,
- all data sets.

The DSN within a message element is chosen as shown in Table 4.

Table 4 – Data set number

Data set number (DSN)	Target
0	Current data set
1 to 253	Specific data set
254	All data sets except the current data set
255	All data sets

8.2.4.4 Programme service number (PSN)

The programme service number (PSN) permits a message element to operate a number of services within one or more data sets and the corresponding addressing is shown in Table 5.

Table 5 – Programme Service Number

Programme service number (PSN)	Target
0	Special PSN for main service of specified data set(s)
1 to,255	Specific service within data set(s)

8.3 Message codes

8.3.1 General

Message codes are described in Annex A and Annex G. Different classes of message are identified.

8.3.2 Remote and configuration commands

These commands permit the control of various functionality options of encoders or permit the request of messages from the encoders in a case of bi-directional transmission mode.

8.3.3 RDS messages

These messages are related to all the RDS features that have to be processed by an encoder.

8.3.4 Handling of RDS message bits declared "rfu"

Each bit from each group and block should be allowed to be used from the encoder point of view without any limitation. When IEC 62106-2 reads "rfu" (reserved for future use), this does not mean it is a forbidden bit or byte: it is just not specified yet.

To permit testing new possibilities using some of the "rfu" bits in whatever group, the encoder shall thus allow the user to do so and not block anything.

8.3.5 Status messages

These messages are used in bi-directional transmission mode to transmit information from an encoder to another device.

8.3.6 Specific messages

These types of messages are not allocated in this specification and concern specific and internal functionality that can be needed by encoder manufacturers. Specific codes are reserved for these types of message and should not be used for other features.

8.4 Description of data handling

The data is transmitted to the encoder using the specified commands described in Annex A, and stored in memory in accordance with the encoder software model, see Clause 5.

8.5 Group sequence configuration

8.5.1 Basic principles used

The encoder shall be informed about the order in which the group types used shall be transmitted and about the appropriate transmission rate for each transmitted group type.

A group sequence (GS) enables the broadcaster/transmission operator to specify an interval between two occurrences of the same group and a group sequence thus specified is always cyclic.

With this method, also the desired repetition rate for every group type is implicitly defined in a very flexible way for the broadcaster. There are, however, special transmission conditions, which are described in 8.5.5.

8.5.2 Group sequence determination

This is achieved with the "Group sequence" command, (MEC 0x16 for data-stream 0 or MEC 0x61 for the upper data-streams) which is treated by the encoder like a group enable command. When a specific group is encountered in the sequence, data relating to that type is transmitted, if available.

An example for defining the group sequence for data-stream 0 including the use of ODA application groups is given in Annex H.

8.5.3 Extended group sequence command

The extended group sequence commands (MEC 0x38 for data-stream 0, or MEC 0x83 for the data upper streams) enable alternative groups to be transmitted if the specific group type within the group sequence is not available. If no alternative group is specified, then the group type is not generated and thus effectively skipped. The next group type in the sequence is used instead.

8.5.4 Relative priority group sequence command

This command permits the alteration of the relative priority of ODA groups transmitted with immediate priority (MECs 0x43 for data-stream 0, or MEC 0x53 for the upper data-streams).

8.5.5 Special transmission conditions

8.5.5.1 Insertion of the type 4A group (CT)

The type 4A group is not allowed in the group sequence. If the CT function is set to "On" (see CT-on/off command MEC 0x19), a type 4A group is inserted automatically by the encoder at the edge of the minute.

During the insertion of a type 4A group, the specified group sequence is suspended and immediately continued thereafter. This action has the highest priority over any other event (e.g. inserting a type 14B group due to the change of the TA flag).

8.5.5.2 Insertion of type 14B group bursts

The type 14B group is not allowed in the group sequence. In order to turn "on" the TA flag for EON services, type 14B group bursts are inserted automatically by the encoder as controlled with the EON TA control command (MEC 0x15) interrupting the given group sequence as a consequence.

8.5.5.3 Insertion of type 15B group bursts

Similar to the insertion of type 14B group bursts, type 15B group bursts are inserted automatically by the encoder as controlled with the TA control command (MEC 0x2A) when the TA flag for the main service changes and are also not allowed in the group sequence.

8.6 Handling of ODA data

8.6.1 Using ODAs on data-stream 0

8.6.1.1 Basic principles

For any new RDS application using the Open Data Application (ODA) feature specified in IEC 62106-2, the coding method is either part of IEC 62106-6, or not at all part of the RDS standard. In both cases, an application is registered using the procedure described in IEC 62106-3 and when it concerns a public ODA showing exactly how the data should be transported in blocks 2, 3 and 4. An application identification code (AID) is assigned, using the 3A type group, so that each ODA has its unique AID, which is published in the ODA register.

When an ODA is transmitted by a transmission provider, the 3A groups inform the receiver in which group number and type the data for a specific application can be found. The AID which identifies an ODA shall be sent using the 3A group at least once every 5 s. The value to be chosen depends on the requirements of the ODA.

8.6.1.2 Special transmission modes

The transmission of data in accordance with the group sequence (MEC 0x16) and extended group sequence (MEC 0x38) does sometimes not offer the timing constraints necessary for certain ODA applications, and so two additional mechanisms have been specified to help ODA developers to increase the flexibility of the RDS resource allocation: "Burst mode" transmission (MEC 0x44), and "Spinning wheel" mode transmission (MEC 0x45).

To offer a flexible priority setting for different ODA applications, the ODA data (MEC 0x46) is sent to the encoder with one of the following priorities: "normal", "extremely urgent", or "immediate" transmission.

A group sent with "normal" priority will be added to the specified ODA data buffer for transmission in accordance with the group sequence. A group sent with "extremely urgent" priority will bypass the ODA data buffer and will be sent as soon as possible in accordance with the group sequence. A group sent for "immediate" transmission is immediately transmitted, irrespective of the group sequence, but respecting the higher priority for the 4A groups.

The relative priority setting (MEC 0x43) for different groups can also be configured in order to explicitly define the relative priority for groups competing to be transmitted outside of the group sequence: e.g. 14B, 15B and repetitions of ODA "Burst mode" groups.

8.6.2 Using ODAs on the upper data-streams 1 to 3

8.6.2.1 Assignment signalling

RDS2 is fully based on the usage of ODAs. On the upper data-streams, all data is organized as C-type groups. The principle behind using these ODAs is fully identical to using ODAs on data-stream 0, where each ODA has its own assignment group 3A to signal the presence of an ODA, identified through its AID code.

On the upper data-streams 1 to 3, an ODA channel in the range 0 to 63 is assigned by an assignment signalling group (AS). This AS group can carry additional data for the ODA in accordance with methods 1 to 4, as specified in IEC 62106-2.

Channel numbers 0..15 are reserved for ODAs using RFT. For this type of ODA, only assignment method 1 is used, where the additional data comes in the format of variants 0 to 15, whereby variants 0..7 are file-specific, and variants 8..15 are related to the ODA itself.

Two alternatives are specified to instruct the encoder to insert assignment groups:

– Alternative 1:

To assign a channel to an AID MEC0x50 is used. This MEC is used for methods 1..4, and with RFT, the not-file-specific variants 8..15. For the file-specific variants 0 to 7, MEC 0x57 is used to define variants 0 and 1, and variants 2 to 7 are defined using MEC0x58. For the transfer of the file data itself, MEC0x57 is used.

– Alternative 2:

MEC0x51 is used to assign a channel to an AID and to assign the additional data for methods 1..4, including the ODDAs which are using RFT. For the transfer of file data, MEC0x55 is used.

The broadcaster/transmission operator can decide to use either Alternative 1, or instead Alternative 2. The encoder will in both cases output the respective AS groups as specified in IEC 62106-2.

AS groups on the upper data-streams are not allowed in the group sequence definition, specified by MEC 0x61. They are inserted automatically by the encoder, thus interrupting the group sequence specified with MEC 0x61 for the respective data-stream(s) to be used by the ODA(s) in question. AS groups are always sent in the same stream in which the actual ODA data is sent.

The encoder will transmit variants 0 and 2 to 7 in the same time window during which the file to which these variants belong is transferred. Variant 1 has priority and is inserted into the GS immediately after the file chunk was transmitted to which this CRC belongs.

When the ODA uses external files, even if only occasionally, there can be a conflict for the automatic insertion caused by the AS group spacing chosen in MECs 0x50 and with external files in MECs 0x57/58 in the case of Alternative 1. The same can occur in Alternative 2 with the group spacing chosen in MECs 0x51 and 0x55. In both cases the respective AS group variants shall then always be inserted by the encoder in ascending order.

8.6.2.2 Special transmission modes

The transmission of ODA data requires signalling of the group sequences (MEC 0x61) and extended group sequences (MEC 0x83).

To offer the possibility of flexible priority settings for different ODA applications, the ODA data is sent to the encoder with one of the following priorities: "normal", "extremely urgent", or for "immediate" transmission.

ODA data sent for "immediate" transmission is immediately transmitted, irrespective of the group sequence, but respecting the higher priority on each active upper data-stream. The relative priority for C-type groups can be set by MEC 0x53.

For Alternative 1, burst mode (MEC 0x54) in the upper data-streams can be used only with ODA data groups (MEC 0x56). For AS groups, a different (non-customisable) burst mode can be used with MEC 0x50.

For Alternative 2, bursts defined by MEC 0x54 can be used with all ODA groups.

8.6.2.3 Tunnelling

All legacy data and ODAs designed for data-stream 0, using group types 0 to 15 with versions A or B, can be transmitted using the upper data-streams 1 to 3, being tunnelled within group type C, which is the only group type that can be used on the upper data-streams. The method to be used is specified in IEC 62106-2. To achieve this, the RDS2 encoder replaces the two bytes of the PI code in block 1 of each A or B group by two bytes of 0x00 each. In doing so, it encapsulates legacy A and B type in a C-type.

The group sequence on the upper data-streams 1 to 3 is set with MEC 0x61. Using this MEC, the transmission provider has to indicate in which sequence which A and B type groups shall be distributed on each of the data-streams 1 to 3.

8.6.2.4 Handling of RFT file transfers

To transfer files on the upper data-streams, the dedicated FID=00 is used with the FN=10yyyy that permits the identification with the four bits yyyy, 0 to 15, pipes that can be used to transfer files.

The technique used is specified in IEC 62106-2, which also states the maximum file size permitted (163 kB). Any given file that is to be transferred using the RFT protocol, shall be sent to the encoder using either MEC 0x57 (Alternative 1) or instead MEC 0x55 (Alternative 2) in UECF frames of maximum 244 file data bytes (Alternative 1) or 246 file data bytes (Alternative 2). This file data is stored in a dedicated buffer. The groups belonging to the same file are stored in the same specific buffer.

A toggle bit, managed by the encoder, is used to mark groups belonging to the same file in any given pipe. This is done to permit the transfer of a sequence of different files and to help the receiver to store the respective groups. Groups that all belong to the same file can thus be easily identified.

The broadcaster or transmission operator shall configure the encoder and shall decide which of the upper data-streams (MEC 0x61) and which channel/pipe is to be used for an ODA.

8.6.2.5 File sequence management

The RDS server determines when to send which file using MEC 0x59. When the file sequence is fixed as described in the example of the logo transmission in Annex I, the file sequencing can be pre-determined in the encoder using this MEC.

If the file sequence is variable, this is an application issue and not something for the encoder to handle.

Annex A (normative)

UECP message command repertoire

A.1 Message command format

The message description is made in accordance with Table A.1. The first column indicates the field name of the message that is detailed in the second column.

Table A.1 – Message command format

Field name	Byte definition	Comments		
	<table border="1" style="margin: auto; border-collapse: collapse;"> <tr> <td style="padding: 2px;">MSB</td> <td style="padding: 2px;">LSB</td> </tr> </table>	MSB	LSB	
MSB	LSB			
MEC	<table border="1" style="margin: auto; border-collapse: collapse;"> <tr><td style="height: 15px;"> </td></tr> </table>			
[DSN]	<table border="1" style="margin: auto; border-collapse: collapse;"> <tr><td style="height: 15px;"> </td></tr> </table>			
[PSN]	<table border="1" style="margin: auto; border-collapse: collapse;"> <tr><td style="height: 15px;"> </td></tr> </table>			
[MEL]	<table border="1" style="margin: auto; border-collapse: collapse;"> <tr><td style="height: 15px;"> </td></tr> </table>			
.MED	<table border="1" style="margin: auto; border-collapse: collapse;"> <tr><td style="height: 15px;"> </td></tr> </table>			

[,..] optional

Each element in Table A.1 represents one byte where the bits are numbered from 7..0 (from left to right). For transmission of a respective message, each byte is represented by two hex symbols whose permitted range is indicated in the respective element. The message structure used is explained in Clause 8. Symbol 00...XX or 0...X, 0...X specifies the range of the hex value that may be used.

The third column gives comment information of the context of the table. A hex symbol means that any hex value may be used. Any other information describes the nature of the data that is put in the table.

The coding of all RDS features is in the same format as used in IEC 62106-2, IEC 62106-3 or IEC 62106-6 and IEC 62106-9, unless otherwise specified.

A.2 Commands for A or B-type groups on data-stream 0

A.2.1 PI / MEC 0x01

Function: to set the PI code of the specified programme service(s) of the specified data set(s).

Format:

	MSB	LSB	
MEC	01		
DSN	00..FF		
PSN	00..FF		
MED	00..FF		PI (MSB)
MED	00..FF		PI (LSB)

Coding of PI is in accordance with IEC 62106-2.

Example: <01><00><01><C2><01>

Set PI code in current data set for programme service 1 to C201.

A.2.2 PS / MEC 0x02

Function: to set the PS name of the specified programme service(s) of the specified data set(s).

Format:

	MSB	LSB	
MEC	02		
DSN	00..FF		
PSN	00..FF		
MED	20..FE		PS character 1
MED	20..FE		PS character 2
MED	20..FE		PS character 3
MED	20..FE		PS character 4
MED	20..FE		PS character 5
MED	20..FE		PS character 6
MED	20..FE		PS character 7
MED	20..FE		PS character 8

Coding of PS is in accordance with IEC 62106-2.

Example: <02><00><02><52><41><44><49><4F><20><31><20>

Set PS in current data set for programme service 2 to >RADIO_1

A.2.3 Long PS / MEC 0x21

Function: to set the Long PS name of the specified programme service(s) of the specified data set(s). For the LPS the UTF-8 character coding is used.

Format:

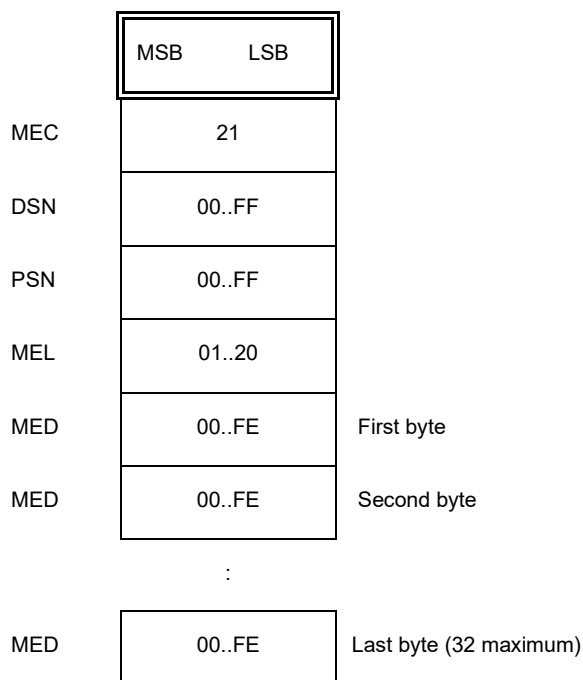

Coding of LPS is in accordance with IEC 62106-2. 0x0D is used to terminate the string if fewer than 32 bytes are used.

EXAMPLE 1: <21><00><02><0F><46><72><61><6E><63><65><20><4D><75><73><69><71><75><65> <0D>

Set LPS in current data set for programme service 2 to >France_Musique<

or

EXAMPLE 2: <21><00><02><0F><52><61><64><69><6F><20><4D><C3><BC><6E><63><68><65><6E><0D>

Set LPS in current data set for programme service 2 to >Radio_München<

NOTE Both above LPS examples are terminated with code <0D> because they are shorter than 32 bytes.

A.2.4 Data group for PTYI / MEC 0x04

Function: to set the decoder information and dynamic PTY indicator codes of the specified programme service(s) of the specified data set(s).

Format:

	MSB	LSB	
MEC	04		
DSN	00..FF		
PSN	00..FF		
MED	00..0A		Bit 0: reserved for future use, default = 0 Bit 1: reserved for future use, default = 0 Bit 2: reserved for future use, default = 0 Bit 3: dynamic PTY Indicator, 0=static or 1= dynamic

Coding of DI – PTYI is in accordance with IEC 62106-2.

EXAMPLE: <04><00><03><08>

Set DI/PTYI to dynamic PTY in current data set, for programme service 3.

A.2.5 TP – TA / MEC 0x03

Function: to set the traffic announcement and traffic programme bits.

Format:

	MSB	LSB	
MEC	03		
DSN	00..FF		
PSN	00..FF		
MED	00..03		Bit 0: TA Bit 1: TP

Coding of TA – TP is in accordance with IEC 62106-2.

EXAMPLE: <03><00><05><02>

Set on current data set TP = 1 and TA = 0, for programme service 5.

A.2.6 PTY / MEC 0x07

Function: to set the Programme Type information of the specified programme service on the specified data set(s).

Format:

	MSB	LSB	
MEC	07		
DSN	00..FF		
PSN	00..FF		
MED	00..1F		PTY

Coding of PTY is in accordance with IEC 62106-2.

EXAMPLE: <07><00><05><08>

Set PTY to 8 in current data set, programme service 5.

A.2.7 PTYN / MEC 0x3E

Function: to set the programme type name of the specified programme service on the specified data set(s).

Format:

	MSB	LSB	
MEC	3E		
DSN	00..FF		
PSN	00..FF		
MED	20..FE		PTYN character 1
MED	20..FE		PTYN character 2
MED	20..FE		PTYN character 3
MED	20..FE		PTYN character 4
MED	20..FE		PTYN character 5
MED	20..FE		PTYN character 6
MED	20..FE		PTYN character 7
MED	20..FE		PTYN character 8

Coding of PTYN is in accordance with IEC 62106-2.

EXAMPLE: <3E><00><02><46><6F><6F><74><62><61><6C><6C>

Set PTYN in current data set for programme service 2 to >Football<.

A.2.8 RT / MEC 0x0A

Function: to set RadioText.

Format:

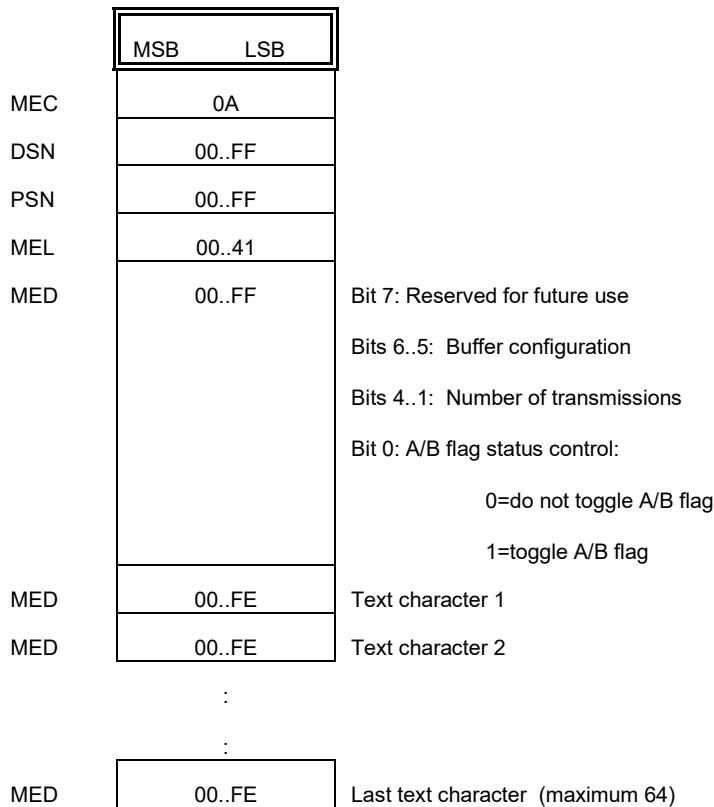

Coding of RadioText is in accordance with IEC 62106-2.

If the buffer is empty, then no RadioText is transmitted.

If a message is received with MEL = 00, then the buffer is emptied and therefore transmission ceases. This may also be achieved with MEL = 01 with bits 5 and 6 of the MED equal to 0.

If the buffer contains only one message, then transmission is repeated indefinitely, despite the defined number of transmissions. If further messages are added, then each message (including the first) is transmitted as defined by its number of transmissions entry, within an overall indefinite cycle as shown in Figure A.1.

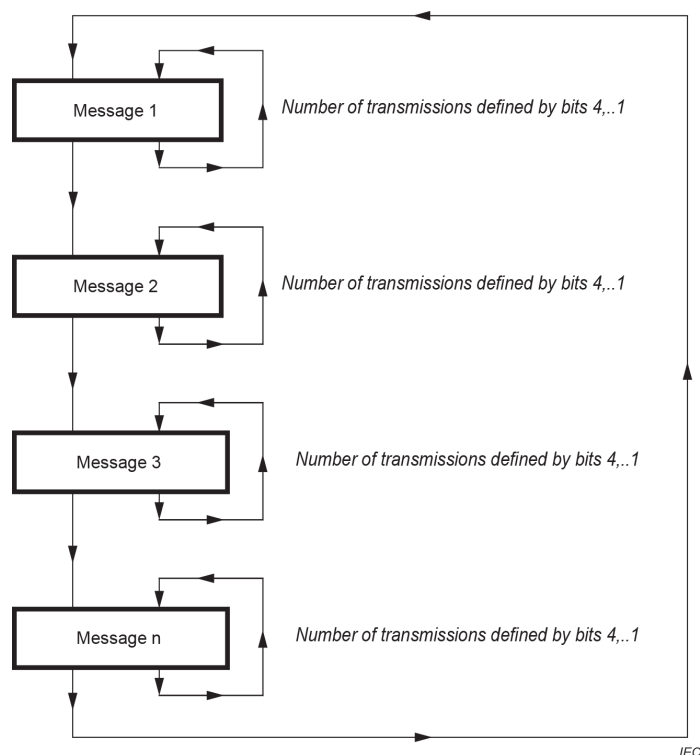

Figure A.1 – Message transmission cycle diagram

Bits 4 to 1	Number of transmissions
0	Indefinite transmissions
1 to F	Hex value of the number of transmissions of each individual message
Bit 6	Bit 5 Buffer configuration
0	0 The RadioText buffer is completely flushed then, if MEL is greater than 01, the specified RadioText message is placed in the buffer.
0	1 Reserved
1	0 Add specified RadioText message to the RadioText buffer. The RadioText messages within the buffer are transmitted cyclically. Each message is repeated individually, within the cycle, a number of times as specified in Bits 4..1.
1	1 Reserved

EXAMPLE: <0A><00><01><04><0B><52><44><53>

Send to current data set, programme service 1. This message causes the buffer to be flushed, the A/B flag to be toggled and the text >RDS< is transmitted indefinitely.

<0A><00><01><05><51><74><65><78><74>

Send to current data set, programme service 1. This, message adds another RadioText message >text< to the buffer to be repeated 8 times. The previous message and this message are cycled. >RDS< is sent five times, then >text< 8 times and so on.

Request Message Command (see A.6.19):

To request the RadioText, the following format is required:

	MSB	LSB	
MEC	17		
MEL	04		
MED	0A		Code of requested message
MED	00..FF		DSN
MED	00..FF		PSN
MED	00..FF		RadioText buffer number

If the requested RadioText buffer is empty, the MEL is set to zero in the reply and no data follows.

A.2.9 AF / MEC 0x13

Function: to edit AF data in the specified data set(s) of the specified programme service(s).

Format:

	MSB	LSB	
MEC	13		
DSN	00..FF		
PSN	00..FF		
MEL	03..FB		
MED	00..FF		Start location (High)
MED	00..FF		Start location (Low)
MED	01..FF		AF data
MED	01..FF		AF data
	:		
	:		
MED	01..FF		AF data
MED	00		Terminator, if necessary

Coding of AF is in accordance with IEC 62106-2.

The PSN shall be a main service in the addressed data set(s). An AF value of 00 indicates the end of the AF list(s) loaded into memory. The AF list terminator 00 indicates that the transmission of AF data has to restart from location 00 00 in the specified AF memory. The start location defines the offset in AF codes from the beginning of the AF memory used for the respective programme service, at which the new data is to be stored. If the start location is set to FF FF, then the AF data is appended at the location of the first terminator 00, of the specified AF memory. In this case the terminator 00 is required in the supplied message.

In loading the AF codes into memory, no distinction is made between the different Methods A or B. The AF list(s) have to be structured in pairs as specified in IEC 62106-2.

EXAMPLE: <13><00><01><07><00><00><E2><15><27><CD><00>

AFs for current data set, programme service 1, offset by 0 AF codes, are set to frequency codes E2 15 27 CD (2 frequencies follow, 89,6 MHz, 91,4 MHz and the filler code).

Request Message Command (see A.6.19):

To request the AF data, the following format is required:

	MSB	LSB	
MEC	17		
MEL	05		
MED	13		Code of requested message
MED	00..FF		DSN
MED	00..FF		PSN
MED	00..FF		Start location (high)
MED	00..FF		Start location (low)

A.2.10 EON-AF / MEC 0x14

Function: to set EON-AF data on the specified data set(s) of the specified programme service(s).

Format:

	MSB... ..LSB	
MEC	14	
DSN	00..FF	
PSN	00..FF	
MEL	04..FB	
MED	00..FF	Start location (high)
MED	00..FF	Start location (low)
MED	04..0A	AF data (variant code of group type 14A)
MED	01..FF	AF data
MED	01..FF	AF data
	:	
	:	
MED	00	Terminator, if necessary

AF data is prepared in three-byte units for direct coding in type 14A groups. The first byte of each three designates the variant code in the range 4..10. An AF value of 00 terminates the AF list(s). The start location defines the offset in bytes (including the variant codes) from the beginning of the AF memory used for the respective programme service, at which the new data is to be stored. The EON AF list terminator 00 indicates that the transmission of AF data has to restart from location 00 00 in the specified EON AF memory. If the start location is set to FF FF, then the EON AF data is appended at the location of the first EON AF list terminator of the specified EON AF memory. In this case the terminator is required in the supplied message.

The specified programme service shall be an EON service in all addressed data set(s).

The EON-AF lists shall be as in IEC 62106-2.

EXAMPLE: <14><00><01><09><00><00><05><15><19><05><18><10><00>

In the current data set, programme service number 1, AF memory location offset by 0 AF codes, set two mapped frequencies with variant code 5, main frequency 89,6 MHz, mapped frequency 90,0 MHz, variant code 5, main frequency 89,9 MHz, mapped frequency 89,1 MHz.

Request Message Command (see A.6.19):

To request the EON – AF data, the following format is required

	MSB	LSB	
MEC	17		
MEL	05		
MED	14		Code of requested message
MED	00..FF		DSN
MED	00..FF		PSN
MED	00..FF		Start location (high)
MED	00..FF		Start location (low)

A.2.11 ECC and other slow label settings / MEC 0x1A

Function: to set data for group type 1A, block 3.

Format:

	MSB	LSB	
MEC	1A		
DSN	00..FF		
MED	00..7F		Bit 7: Reserved for future use, default 0 Bits 6..4: Variant code Bits 3..0: Data MSB, default 0000
MED	00..FF		Data LSB

For each Variant code 0..7, data can be set in the range 000..FFF.

Coding of ECC is in accordance with IEC 62106-4. ECC is carried in block 3, variant 000 of group type 1A. If ECC is used, group type 1A shall be in the group sequence.

EXAMPLE: <1A><04><00><E2>

Set the ECC code in the data set 4 to E2, using variant 000 for the ECC slow label data field 0E2.

Request Message Command (see A.6.19):

To request Slow labelling variant codes, the following format is required:

	MSB	LSB	
MEC	17		
MEL	03		
MED	1A		Code of requested message
MED	00..FF		DSN
MED	00..07		Variant Code

A.2.12 Linkage information / MEC 0x2E

Function: to set Linkage information, variant 12 of block 3 of type 14A groups. The Linkage Actuator LA (MSB) is also in group type 1A, block 3.

Format:

	MSB	LSB	
MEC	2E		
DSN	00..FF		
PSN	00..FF		
MED	00..FF		Link information MSB
MED	00..FF		Link information LSB

The Linkage information is mapped as applied in type 14A groups.

If the PSN specified is the main PSN, the most significant bit (the Linkage Actuator LA) is sent in group type 1A and the Linkage Set Number LSN is transmitted using a group type 14A in which the PI ON= PI TN.

EXAMPLE: <2E><02><03><81><23>

Set Linkage information in data set 2, programme service 3, to 0x8123. The Linkage actuator is set to 1. If programme service 3 is the main PSN, the Linkage actuator will be transmitted in group type 1A and 14A with value 1.

A.2.13 Free-format data in type A or B group / MEC 0x24

Format: to add a group to the free-format buffer for that group type.

Format:

	MSB	LSB	
MEC	24		
MED	00..1F		Bits 4..1: Group type number
MED	00..7F		Bits 0: Group version A or B Bit 7: Set to 0 Bits 6..5: Buffer configuration Bits 4..0: Block 2, 5 bits
MED	00..FF		Block 3 (MSB)
MED	00..FF		Block 3 (LSB)
MED	00..FF		Block 4 (MSB)
MED	00..FF		Block 4 (LSB)

If free-format data is present in the buffer for the scheduled group, it will be transmitted instead of the "internally generated RDS data". An encoder schedules group transmission in accordance with its group sequence or higher priority event. If free-format data is present in the buffer for a group type which is not scheduled for transmission, the free-format data will not be transmitted. Therefore, the necessary group for free-format data shall be inserted into the group sequence in addition to the "normal RDS groups".

Bit 6	Bit 5	Buffer configuration
0	0	Information transmitted once only and removed after transmission
0	1	Reserved
1	0	For cyclic transmission, free-format information sets (37 bit) are added to the data buffer
1	1	Remove all free-format information sets (37 bit) from the data buffer

Example: <24><07><0C><00><00><AB><DE>

Data for group type 3B, block 2 data is 0x0C, block 3 data will be overwritten by PI code because type B group is selected, block 4 data is 0xAB DE. The data is transmitted only once.

A.3 Commands for ODAs on data-stream 0

A.3.1 Group type 3A ODA configuration and short message command / MEC 0x40

Function: to link the ODA group type code to an AID, in group type 3A. The command also edits the group type 3A short message bits in block 3.

Format:

	MSB	LSB	
MEC	40		
MED	00..1F		Application group type code
MED	00..FF		AID (MSB)
MED	00..FF		AID (LSB)
MED	00..03		Bits 1..0 Buffer configuration
MED	00..FF		Short message (MSB)
MED	00..FF		Short message (LSB)
MED	00..FF		ODA data input timeout, where: 0 = off and 1 – 255 minutes can be signalled

In the first MED, the 5-bit application group type code in block 2 of A- and B-type groups is coded. The group type A and B codes to be used are the ones specified in IEC 62106-2.

Bits 7 to 5: Set to 0

Bits 4 to 1: Group type

Bit 0: Group version, 0=A,1=B

The application group type code addresses the application, as only one group type per application is permitted. When configured for cyclic transmission, loss of application data input to the encoder for longer than the data input timeout, will be signalled by type 3A groups of this AID with the application group type code set to 0x1F or binary coded as 11111 (see [7], Table 1).

An application group type code 00 is used to indicate that there is no associated group, i.e. only group type 3A is used.

Buffer configuration:

Bits 1 and 0 of the fourth MED are coded as follows:

Bit 1	Bit 0	Buffer configuration
0	0	Information transmitted once only and removed after transmission
0	1	Reserved
1	0	For cyclic transmission, type 3A groups are added to the specified buffer
1	1	Remove all type 3A groups from the specified application group type buffer

EXAMPLE: <40><16><12><34><02><AB><CD><0A>

Assign group type code 11A to AID >0x1234<.

The message >0xABCD< is added to the buffer for cyclic transmission. The ODA data input timeout is set to 10 min

Request Message Command (see A.6.19):

To request the Application Group type code used for ODA configuration.

	MSB	LSB	
MEC	17		
MEL	01..02		
MED	40		Code of requested message
MED	00..0B		[Application group type code]. If none specified, data for all application group type codes will be packed into separate message elements inside the same frame. But if this is too long for a single frame, then the error message 09 "not acceptable" will be generated.

A.3.2 ODA assignment group usage sequence signalling / MEC 0x41

Function: to set the frequency of the ODA assignment group type signalling in the specified data set(s) with group type 3A.

Format:

	MSB	LSB	
MEC	41		
DSN	00..FF		
MEL	00..FC		
MED	00..1B		Bits 7..5: Set to 0 First application group type code Bits 4..1: group type Bit 0: group version, 0=A,1=B
			:
			:
MED	00..1B		Bits 7..5: Set to 0 n th application group type code Bits 4..1: group type Bit 0: group version, 0=A,1=B

The available application group type codes are defined in IEC 62106-3:2018, Table 1.

Using MEC 0x16 within the group sequence, the ODA application group type code to be transmitted is signalled to the encoder by the group usage sequence specified. 3A groups are then transmitted in accordance with the group sequence determined by MEC 0x16. However, how often a specific ODA application group is signalled by means of a 3A group, is the purpose of this optional MEC 0x41.

If not used, each application group type code is signalled by the 3A assignment group in alternation as ODA1, ODA2; ODA1, ODA2 etc. Using MEC 0x41 a higher 3A signalling priority can be defined for the application.

EXAMPLE: <41><00><04><16><16><16><12>

Set a new ODA assignment group sequence in the current data set as: > 11A, 11A, 11A, 9A <. Consequently, type 3A groups will be transmitted in the ratio 75 % conveying type 11A group information and 25 % conveying type 9A group information. The 11A application group is thus signalled 3 times more often by the assignment group 3A than the 9A application group.

Request Message Command (see A.6.19):

To request the ODA Identification group usage sequence, the following format is required:

	MSB	LSB	
MEC	17		
MEL	02		
MED	41		Code of requested message
MED	00..FF		DSN

A.3.3 ODA relative priority group sequence / MEC 0x43

Function: to set the relative priority level for groups transmitted using the ODA data command with "immediate" priority (see 8.6.1).

	MSB	LSB	
MEC	43		
MEL	00..FD		
MED	00..1F		Highest relative priority group
			Bits 7..5: Set to 0
			Bits 4..1: Group type
			Bit: 0 Group version, 0=A, 1=B
			:
			:
MED	00..1F		Lowest relative priority group

If no ODA relative priority group sequence is specified, the priority of groups sent with the ODA data command and "immediate" priority is below the other priorities specified in IEC 62106-2.

Setting the ODA relative priority group sequence enables the relative priority of groups to be altered.

EXAMPLE: <43><03><16><1F><1D>

Type 11A groups sent, using the ODA data command, will be given a higher priority for transmission than type 15B and type 14B groups generated by the encoder. Other high priority groups, such as type 4A groups will still have higher priority.

A.3.4 ODA data group repetitions and burst mode / MEC 0x44

Function: to control the generation of the ODA group type code to be repeated or configured for burst mode transmission with MEC 0x46 (see Annex F).

Format:

	MSB	LSB	
MEC	44		
MED	07..1B		Bits 4..0: Application group type code
MED	00..FF		Bits 7..4: Number of repetitions
			Bits 3..0: Spacing

The number of repetitions is indicated in the range 0 to F times (according to relative priority). Spacing is indicated by the minimum number of other groups between two ODA data groups with this application group type code. One repetition means that two ODA data groups with same content are inserted and two means three (one original and two repetitions of the original).

EXAMPLE: <44><16><10>

Transmit two ODA data group type codes 11A, with no groups in between (depending on the priority – see MEC 0x43).

Request Message Command (see A.6.19):

To request the application group type code used for ODA "Burst mode".

	MSB	LSB	
MEC	17		
MEL	01..02		
MED	44		Code of requested message
MED	07..0B		[Application group type code]. If none specified, data for all application group type codes will be packed into separate message elements inside the same frame. But if this is too long for a single frame, then the error message 09 "not acceptable" will be generated.

A.3.5 ODA "spinning wheel" timing control / MEC 0x45

Function: to set the timing parameters for an ODA group type code configured for "Spinning wheel" transmission (see Annex F).

Format:

	MSB	LSB	
MEC	45		
MED	07..1B		Application group type code (see IEC 62106-2 for valid codes)
MED	01..3C		Number of time slots
MED	00..3C		Window time (in seconds)
MED	00..3B		Delay time, relative to beginning of the minute (in seconds).

The number of time slots should be chosen to give an integer number of seconds.

The time from the beginning of the time slot until the beginning of the window time, is the "active time" during which the ODA group type codes may be transmitted.

EXAMPLE: <45><16><0A><03><00>

Sets 10 time slots of 3 s "active time" and 3 s "window time", for the ODA group type 11A, synchronized to the beginning of the minute.

Request Message Command (see A.6.19):

To request the application group type code used for ODA "Spinning wheel mode".

	MSB	LSB	
MEC	17		
MEL	01..02		
MED	45		Code of requested message
MED	07..0B		[Application group type code]. If none specified, data for all Application Group type codes will be packed into separate message elements inside the same frame. But if this is too long for a single frame, then the Error message 09 "not acceptable" will be generated.

A.3.6 ODA data / MEC 0x46

Function: to transmit ODA data in group type 3A.

Format:

	MSB	LSB	
MEC	46		
MEL	05		
MED	00..FF		AID MSB
MED	00..FF		AID LSB
MED	40..43		Configuration: Bit 7: Set to 0 Bit 6: Short message flag set to 1 Bits 5..2: Set to 0 Bits 1..0: Buffer configuration
MED	00..FF		Message (MSB)
MED	00..FF		Message (LSB)

To transmit ODA data within the ODA group signalled for this AID in group type 3A:

	MSB	LSB	
MEC	46		
MEL	06 or 08		08: If group type A 06: If group type B
MED	00..FF		AID MSB
MED	00..FF		AID LSB
MED	00..3F		Configuration: Bit 7: Set to 0 Bit 6: Short message flag set to 0 Bits 5..4: Priority setting (see 8.6) Bits 3..2: Mode selection Bits 1..0: Buffer configuration
MED	00..1F		ODA data, block 2, 5 bits
MED	00..FF		ODA data, block 3 MSB (group type A only)
MED	00..FF		ODA data, block 3 LSB (group type A only)
MED	00..FF		ODA data, block 4 MSB
MED	00..FF		ODA data, block 4 LSB

Bits 1 and 0 of the third MED are coded as follows

Bit 1	Bit 0	Buffer configuration
0	0	Information transmitted once only and removed after transmission
0	1	Reserved
1	0	For cyclic transmission, free-format information sets are added to the specified buffer
1	1	Remove all free-format information sets from the specified free-format buffer

Bits 3 and 2 of the third MED are coded as follows:

Bit 3	Bit 2	Mode selection
0	0	Normal mode
0	1	"Burst mode" (see Annex F and MEC 44)
1	0	"Spinning wheel mode" (see Annex F and MEC 45)
1	1	Reserved

Bits 5 and 4 of the third MED are coded as follows:

Bit 5	Bit 4	Priority setting (see 8.6)
0	0	Normal
0	1	"Extremely urgent". Valid only if the buffer configuration is 00
1	0	Immediate
1	1	Reserved

A group sent with "Extremely urgent" priority will be inserted as soon as possible in accordance with the group sequence.

A group with "immediate" priority will be transmitted immediately, irrespective of group sequence, but respecting the priorities defined in the RDS standard IEC 62106-2, unless the ODA priority group sequence has been configured (see 8.6).

Bit 6 of the third MED is coded as follows:

Bit 6	Short message flag
0	Data for associated ODA group type
1	Data for Group type 3A (ODA short message)

Bit 7 of the third MED is set to zero.

EXAMPLE 1: <46><05><01><23><40><55><AA>

Transmit >55, AA< once only as short message data, in Group type 3A, for ODA-AID 0123.

EXAMPLE 2: <46><08><01><23><00><1F><64><73><82><91>

Transmit >1F, 64, 73, 82, 91< once only as ODA free format data in normal mode and with normal priority in the Group type associated to ODA-AID 0123.

A.3.7 ODA data command access right / MEC 0x47

Function: to enable or disable access to the ODA data command on any port.

Format:

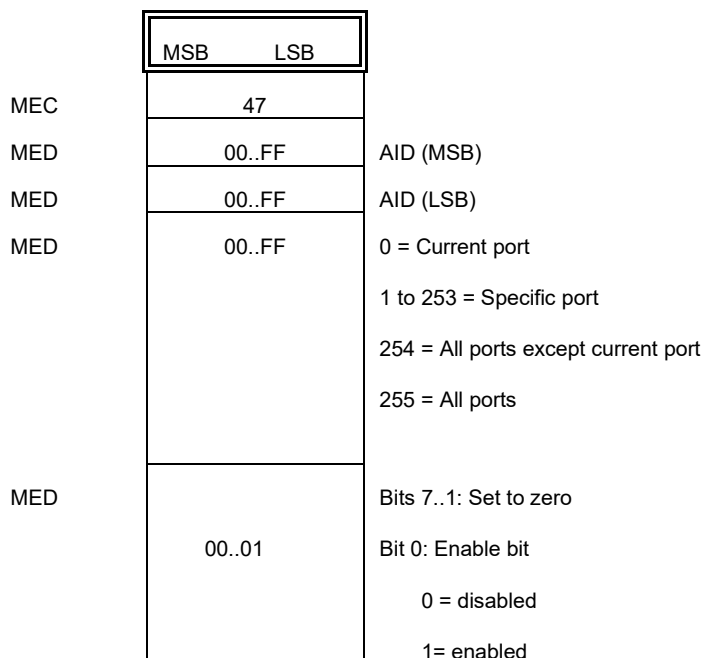

If a wrong or non-existent port number is specified, the encoder should respond with the error message 06: "parameter out of range".

AID FFFF is used to configure access rights for all currently configured AIDs.

EXAMPLE: <47><12><34><02><01>

ODA Data command access right is enabled for AID >1234< on port 2.

Request Message Command (see A.6.19):

To request the ODA Data command access setting, the following format is required:

	MSB	LSB	
MEC		17	
MEL		02	
MED		47	Code of requested message
MED		01..FF	[Port number]. If 0 is specified, then the error message 06 will be generated: "parameter out of range".

Data for all configured AIDs is packed into separate message elements in the same frame.

A.4 Commands for clock setting and control for data-stream 0

A.4.1 Real time clock for CT / MEC 0x0D

Function: to set the date and time.

Format:

	MSB	.LSB	
MEC		0D	
MED		00..63	Last two decimal digits of Year expressed as hex
MED		00..0C	Month
MED		00..1F	Date
MED		00..17	Hours
MED		00..3B	Minutes
MED		00..3B	Seconds
MED		00..63	Value/100 of a second (centiseconds)
MED		00..FF	00...3F: Local Time offset FF= Local Time offset unchanged 40...FE: undefined

Time of day is expressed in terms of Co-ordinated Universal Time (UTC).

The local Time Offset byte should be coded in conformity with IEC 62106-2, as follows:

MSB				LSB			
1	2	3	4	5	6	7	8
Not Used	Not Used	Sign of Local Time Offset	Magnitude of Local Time Offset in multiples of half hours				
		0 = +					
		1 = -					

Date, hours, minutes, seconds and centiseconds are coded as binary numbers and then expressed as a two-digit hex number.

EXAMPLE: <0D><02><09><0C><0A><12><21><0F><02>

The following is to be set: Year is 2002, Month is September, Date is 12, Hour is 10, Minute is 18, Second is 33, centisecond is 15 and Local Time offset is 1 h.

A.4.2 Real time clock correction for CT / MEC 0x09

Function: to set real time clock correction (RTCC) in order to compensate a delay caused by the signal distribution. The adjustment range is between -32 768 ms and +32 767 ms.

Format:

	MSB	LSB	
MEC	09		
MED	00..FF		RTCC higher byte hex
MED	00..FF		RTCC lower byte hex

The real time clock correction RTCC is coded as a 16-bit two's complement number.

EXAMPLE: <09><FF><C6>

Set Real time clock correction to -58 ms.

A.4.3 CT on-off command / MEC 0x19

Function: to enable/disable the transmission of type 4A group.

Format:

	MSB	LSB	
MEC	19		
MED	00..01		Enable/Disable

"01" enables the transmission of type 4A groups and "00" disables it. The time is set with the Real Time Clock Command.

EXAMPLE: <19><01>

Enable transmission of type 4A group.

A.5 Commands for RDS signal alignment and control on data-stream 0

A.5.1 RDS on-off command data-stream 0 / MEC 0x1E

Function: to switch RDS output signal "On" or "Off".

Format:

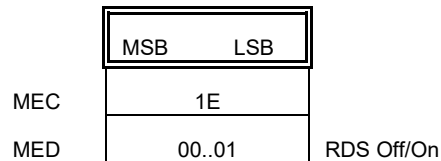

"00" switches RDS "Off", "01" switches "On"

EXAMPLE: <1E><00>

Switch the RDS output signal "Off".

A.5.2 RDS phase for subcarrier 0 / MEC 0x22

Function: to set RDS subcarrier phase shift relative to the phase of the 3rd harmonic of the 19 kHz reference signal for a specified reference table entry.

Format:

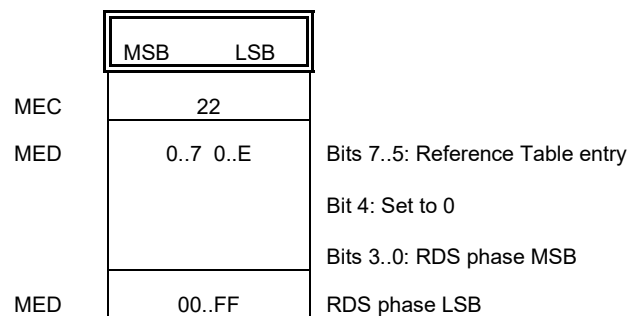

Reference '0' means that the phase is related to all table entries, '1' to '6' identify a specific table entry, '7' is the currently selected table entry.

The RDS phase is expressed in the range from 0° to 359,9°, in steps of 0,1° and converted to a hex number.

Example: <22><45><4C>

Set phase to 135,6° for reference table entry: Input 4.

Request Message Command (see A.6.19):

To request the RDS phase, the following format is required:

	MSB	LSB	
MEC	17		
MEL	02		
MED	22		Code of requested message
MED	00..07		Reference table entry

On a request, with reference table entry set to 0, the data of all reference table entries is returned in separate message elements.

A.5.3 RDS level for subcarrier 0 / MEC 0x0E

Function: to adjust the level of the RDS subcarrier in mV_{p-p} for a specified reference table entry.

Format:

	MSB	LSB	
MEC	0E		
MED	0..7 0..1F		Bits 7..5: Reference table entry
			Bits 4..0: RDS level MSB
MED	00..FF		RDS level LSB

Reference "0" means that the level is related to all table entries, "1" to "6" identifies a specific table entry, "7" is the currently selected table entry. The RDS level is expressed in the range from 0 mV_{p-p} to 8 191 mV_{p-p} and converted to a 13-bit number.

EXAMPLE: <0E><A3><11>

Set RDS level to 785 mV_{p-p} for reference table entry: input 5.

Request Message Command (see A.6.19):

To request the RDS level, the following format is required:

	MSB	LSB	
MEC	17		
MEL	02		
MED	0E		Code of requested message
MED	00..07		Reference table entry

On a request, with reference table entry set to 0, the data of all reference table entries is returned in separate message elements.

A.6 Message name commands control and set-up commands on data-stream 0

A.6.1 Site address / MEC 0x23

Function: to load or remove a site address in the encoder.

Format:

	MSB	LSB	
MEC	23		
MED	00..03		Control Bits
MED	00..03		Site address high
MED	00..FF		Site address low

The range of permitted site addresses is 0x001 – 0x.3FF (10 bit).

The global site address "0" is always defined for the encoder. This address does not need to be included in a downloaded address list and may not be cleared.

Manufacturers may choose to implement a special (individual) site address that cannot be changed or cleared with this command, to prevent lock-out.

Bit 1	Bit 0	Significance of the two control bits
0	0	Remove the specified site address from the list
0	1	Add the specified site address to the list
1	0	Remove all site addresses
1	1	Reserved

On a request, all stored site addresses are returned in separate message elements with control bits set to bit 1 = 0 and bit 0 = 1.

EXAMPLE: <23><01><00><48>

Add the site address 0x0048 to the list of site addresses.

A.6.2 Encoder address / MEC 0x27

Function: to load or remove an encoder address in the encoder.

Format:

	MSB	LSB	
MEC	27		
MED	00..03		Control bits
MED	01..3F		Encoder address

The range of permitted encoder addresses is 01 to 3F hex (6 bits).

The global encoder address "0" is always defined for the encoder. This address does not need to be included in a downloaded address list and may not be cleared.

Manufacturers may choose to implement a special (individual) encoder address that cannot be changed or cleared with this command.

Bit 1	Bit 0	Significance of the two control bits
0	0	Remove the specified encoder address from the list
0	1	Add the specified encoder address to the list
1	0	Remove all encoder addresses
1	1	Reserved

On a request all stored encoder addresses are returned in separate message elements with control bits set to bit 1 = 0 and bit 0 = 1.

EXAMPLE: <27><01><13>

Add the encoder address 0x13 to the list of encoder addresses.

A.6.3 Make PSN list / MEC 0x28

Function: to assign one PSN as the main network service in the specified data set(s) and assign the other PSNs as other networks (EON).

Format:

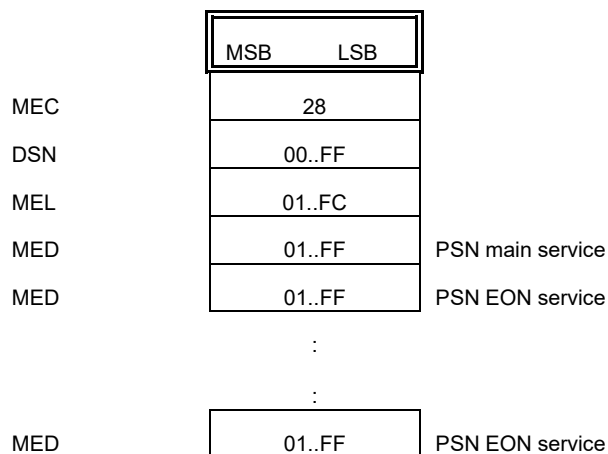

This command establishes the main service and the EON services that will be used in a given data set within the encoder. When issued, the command deletes all data in the specified data set and establishes the programme services from this command. These services will need to be loaded using appropriate commands and then be enabled using the PSN enable command before the output is transmitted. The command is not permitted for the current data set.

EXAMPLE: <28><02><05><03><01><04><09><2F>

In data set 2, assign PSN = 3 as the main service and the PSNs 1, 4, 9 and 47 as EON services.

A.6.4 PSN enable-disable / MEC 0x0B

Function: to enable or disable a specified PSN.

Format:

	MSB	LSB	
MEC	0B		
DSN	00..FF		
MEL	02..FC		
MED	00..01		Bit 0: 0 disable PSN; 1 enable PSN
MED	01..FF		Index of PSN to be enabled/disabled
MED	00..01		
	:		
	:		
MED	00..01		
MED	01..FF		

The main PSN may not be affected. Addressing the main PSN will cause an error code.

EXAMPLE: <0B><03><04><00><06><01><07>

Disable PSN 6 and enable PSN 7 in Data set 3.

A.6.5 EON elements enable-disable / MEC 0x3F

Function: to enable or disable the transmission of a specific EON element for usage in group type 14 for specific PSNs and DSNs. This is achieved by switching on/off a particular variant for transmission in 14A groups and, in the case of TA(ON), the burst signalling of 14B groups. MEC 3F supplements MEC 29 with the possibility of disabling specific elements in specific PSNs of the specific data set DSN.

Format:

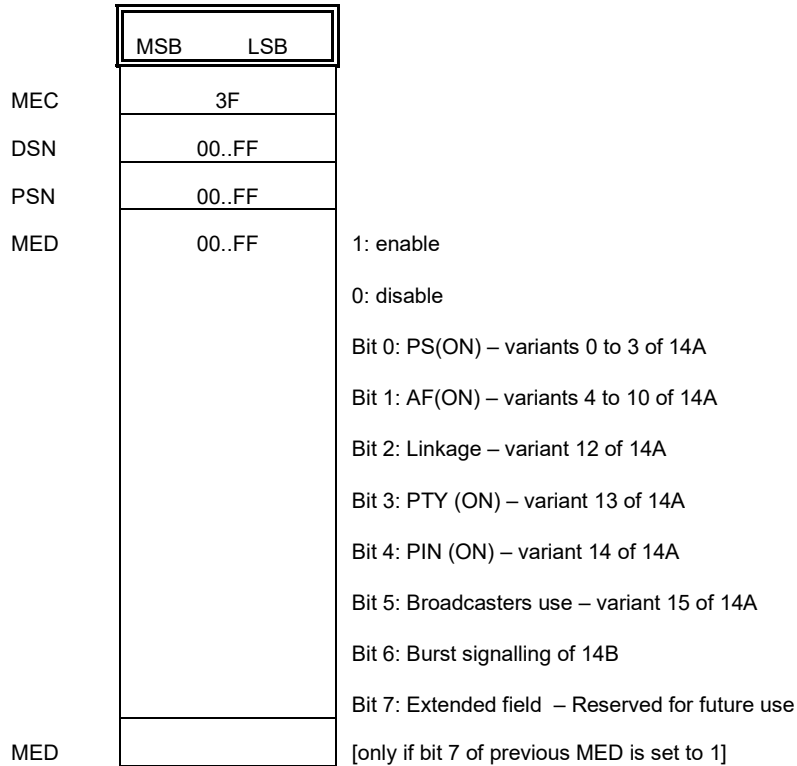

Group types 14A and 14B are defined in IEC 62106-2.

NOTE Variant 13 of the Group type 14A also contains the TA(ON) bit. However, in this particular variant, TA(ON) serves only broadcast monitoring purposes and is not to be interpreted by a receiver for switching to a traffic announcement on another network. This can only be accomplished with the burst of 14B groups. Therefore, control bit 6 permits the switching on or off of each TA(ON) individually to avoid simultaneous cross-referencing to traffic announcements on more than one other network.

EXAMPLE: <3F><03><06><0B>

Enable PS(ON), AF(ON), PTY(ON) in Data set 3 for PSN 6.

A.6.6 Communication mode / MEC 0x2C

Function: to set the communication mode of the encoder.

NOTE In new applications MEC 3B should be used, because it can specify the communication mode for individual ports.

Format:

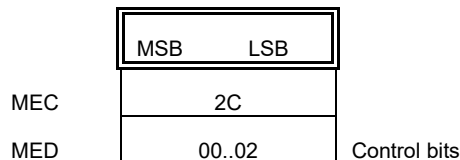

0 means unidirectional mode

1 means bi-directional mode with requested response

2 means bi-directional mode with spontaneous response and the sequence counter is set to 0.

Whenever this command is received, by an encoder, it shall reset the sequence counter to a value of 1.

When changing from mode 2 to any other mode it will not be acknowledged.

EXAMPLE: <2C><01>

The encoder is set to bi-directional mode with requested response.

A.6.7 TA control / MEC 0x2A

Function: to control the generation of type 15B groups in the "On" and "Off" transition.

Format:

	MSB	LSB	
MEC	2A		
MED	00..08		Minimum number of other groups between two type 15B groups (0..8)
MED	0..F 0..F		Bits 7..4: Number of type 15B groups at TA "On" transition Bits 3..0: Number of type 15B groups at TA "Off" transition

In the second MED, 0 specifies that no type 15B group is to be transmitted at the given transition. 1 to E specifies the number of type 15B groups to be transmitted at the given transition. F means the type 15B groups should be transmitted continuously while the respective state is maintained.

EXAMPLE: <2A><01><02>

Transmit two 15B groups, with a gap of >1< between two 15B groups, at the TA "Off" transition.

A.6.8 EON-TA control / MEC 0x15

Function: to control the generation of type 14B groups in this programme for the TA "On" and "Off" transition in the cross-referenced programme.

Format:

	MSB	LSB	
MEC	15		
MED	00..08		Minimum number of other groups between successive 14B groups (0..8)
MED	0..F 0..F		Bits 7..4: Number of 14B groups at TA "On" transition in the cross-referenced programme Bits 3..0: Number of 14B groups at TA "Off" transition in the cross-referenced programme

Group type 14B is defined in IEC 62106-2.

In the second MED, 0 specifies that no type 14B group is to be transmitted at the given transition; 1 to E specifies the number of type 14B groups to be transmitted at the given transition and F

means the type 14B group should be transmitted continuously while the respective state is maintained.

EXAMPLE: <15><01><08>

Transmit eight type 14B groups, with a gap of >1< between two type 14B groups, at the TA "Off" transition in the cross-referenced programme.

A.6.9 Reference input select / MEC 0x1D

Function: to select the 19 kHz reference input in the encoder and apply levels and phase from the corresponding reference table entry.

Format:

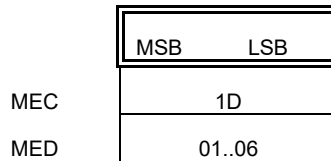

The reference table contains one entry corresponding to each reference input. Each table entry contains level and phase for all streams.

EXAMPLE: <1D><01>

Reference input >1< is selected, as well as level and phase parameters for reference table entry number 1.

A.6.10 Data set select / MEC 0x1C

Function: to select desired data set to be active ("on air").

Format:

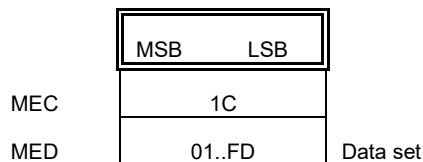

EXAMPLE: <1C><17>

Select data set >23< to be active.

A.6.11 Group sequence determination for data-stream 0 / MEC 0x16

Function: to set the group sequence in the specified data set(s).

Format:

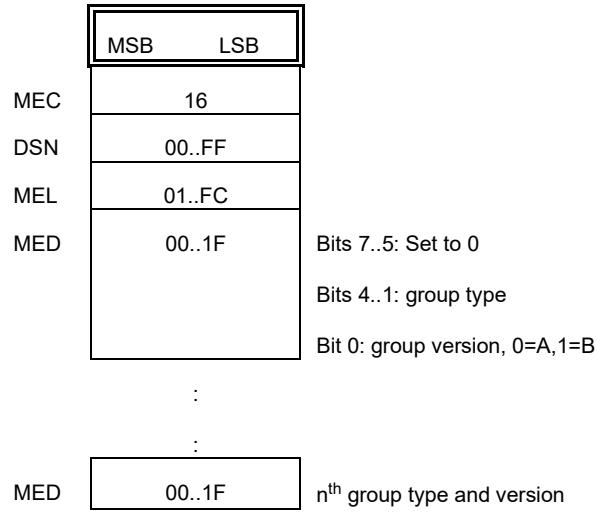

EXAMPLE: <16><00><06><00><04><0E><1C><0D><00>

Set a new group sequence in the current data set as type 0A, 2A, 7A, 14A, 6B, 0A groups.

A.6.12 Extended group sequence for data-stream 0 / MEC 0x38

Function: to set alternative group sequences for use when dynamic buffers are empty of data for particular groups.

Format:

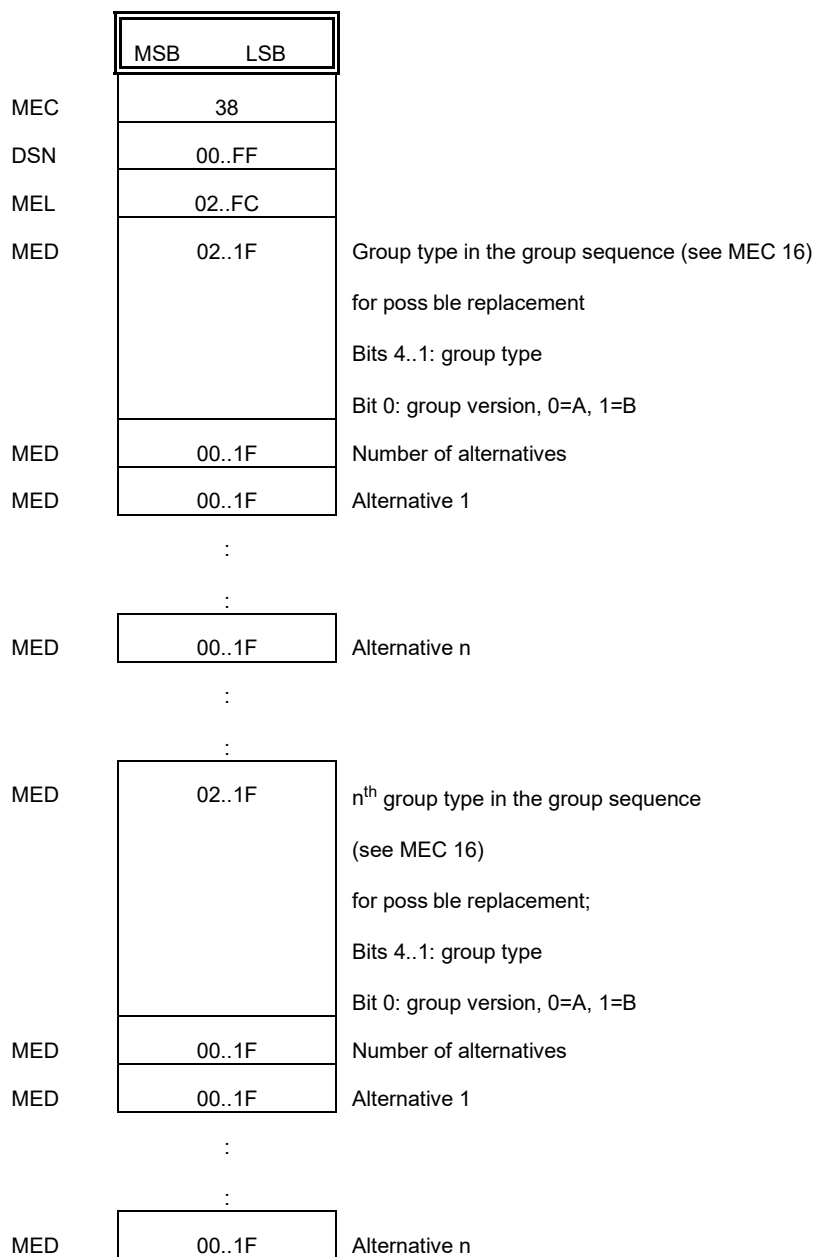

More than one alternative sequence is allowed for the same group type, the list of these alternative sequences being cycled through when there is no data for the replaced group. In the case where there are several alternative sequences for the same group type, the position in the list is not advanced if data is available for the particular group type.

EXAMPLE: <38><01><09><0E><03><10><0C><1C><0E><02><0C><00>

In Data set DSN=1, transmission of the first type 7A group should be replaced, if there is no data, by transmission of a type 8A group, or if the type 8A group buffer is empty by a type 6A group, or if the type 6A group buffer is empty by a type 14A group. The next transmission of a type 7A group for which there is no data should be replaced by transmission of a type 6A group or, if the type 6A buffer is empty, by a type 0A group. The following transmission of a type 7A group for which there is no data should be replaced by the alternatives sequence: type 8A, 6A, 14A groups.

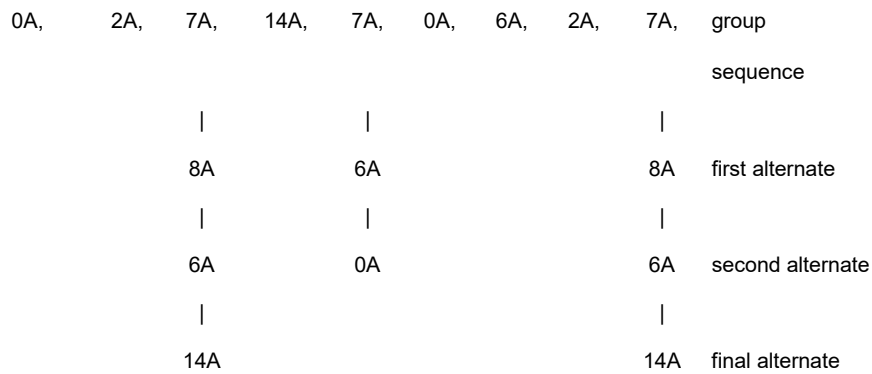

A.6.13 Group variant code sequence for data-stream 0 / MEC 0x29

Function: to set the variant code sequence for a specified group type in the specified data set(s).

Format:

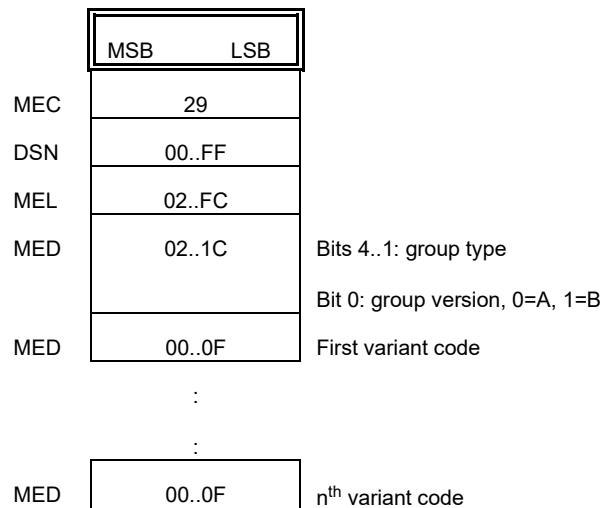

Type 1A and 14A groups may be used. Other groups, which do not utilize variant codes, should be ignored.

EXAMPLE: <29><00><04><02><00><01><06>

Set a new variant code sequence for type 1A groups in the current data set as: >00, 01, 06<.

Request Message Command (see A.6.19):

To request the group variant code sequence, the following format is required:

		MSB	LSB	
MEC		17		
MEL		03		
MED		29		Code of requested message
MED		00..FF		DSN
MED		02..1C		Bits 4..1: group type Bit 0: group version

A.6.14 Encoder access right / MEC: 0x3A

Function: to enable or disable access to any message on any port.

Format:

		MSB	LSB	
MEC		3A		
MED		00..FF		MEC of the command to be accessed FF: Special meaning (see below)
MED		00..FF		0 = Current port 1 to 253 = Specific port 254 = All ports except current port 255 = All ports
MED		00..01		Bits 7..1: set to zero Bit 0: enable bit 0 = disabled 1 = enabled

If a wrong or non-existent port number is specified, the encoder should respond with the Error message 06: "parameter out of range".

If a command is sent that attempts to lock-out the currently used port, the encoder shall generate the Error message 09: "not acceptable".

If the first MED is set to FF, the access right for all MECs on the specified port is modified, with the exception of MEC 0x3A, if the port concerned happens to be the actual port.

EXAMPLE 1: <3A><3A><FE><00>

Coder access right (MEC 0x3A) is disabled on all other ports.

EXAMPLE 2: <3A><01><08><00>

PI change is disabled on port 8.

Request Message Command (see A.6.19):

To request the access setting, the following format is required:

	MSB	LSB	
MEC	17		
MEL	03		
MED	3A		Code of requested message
MED	00..FF		MEC of the requested access right. If 254 or 255 specified, then data for all implemented MECs will be packed into separate message elements inside the same frame. But if this is too long for a single frame, then the Error message 09: "not acceptable" will be generated.
MED	01..FF		Port number. If 0 is specified, then the Error message 06: "parameter out of range" will be generated.

A.6.15 Communications port configuration – Mode / MEC 0x3B

Function: to set the mode of specified communications ports.

Format:

	MSB	LSB	
MEC	3B		
MED	00..FF		0 = Current port 1 to 253 = Specific port 254 = All ports except current port 255 = All ports
MED	00..02		00 Unidirectional mode 01 Bidirectional mode with requested response 02 Bidirectional mode with spontaneous response

Communications modes are described in Clause 7. Changing from Mode 2 to Modes 0 or 1 will not give a spontaneous response.

If a wrong or non-existent port number is specified, the encoder should respond with the Error message 06: "parameter out of range".

EXAMPLE 1: <3B><00><01>

Set bidirectional mode with requested response to currently used port.

EXAMPLE 2: <3B><FF><02>

Set bidirectional mode with spontaneous response to all ports.

Request Message Command (see A.6.19):

To request the mode setting, the following format is required:

	MSB	LSB	
MEC	17		
MEL	01..02		
MED	3B		Code of requested message
MED	00..FF		[Port number]. If 0 or none specified, then data for all installed ports will be packed into separate message elements inside the same frame. But if this is too long for a single frame, then the Error message 09: "not acceptable" will be generated.

A.6.16 Communications port configuration – Speed / MEC 0x3C

Function: to change speed of communications ports.

Format:

		MSB	LSB	
MEC		3C		
MED		00..FF		0 = Current port 1 to 253 = Specific port 254 = All ports except current port 255 = All ports
MED		00..0C		00 No action 01 75 bps 02 150 bps 03 300 bps 04 600 bps 05 1 200 bps 06 2 400 bps 07 4 800 bps 08 9 600 bps 09 19 200 bps 0A 38 400 bps 0B 57 600 bps 0C 115 200 bps

This command shall not be used with any other messages in the same frame to ensure the full response of the encoder is completed.

If a wrong or non-existent port number is specified, the encoder should respond with the error message 06: "parameter out of range".

If Port 255 is selected, then all ports will be affected by the command. Reply to this message, when bi-directional links are used, should use the original speed. All subsequent responses shall be at the new speed.

Care should be taken when changing speed of the "current" port. Setting the wrong speed can lock out all future communication. Therefore, it is required that this command be sent twice to ensure reliability in making speed changes. First, the command is sent at the "original" speed and then it is sent at the "new" speed; if the second command is not recognised by the encoder, within 60 s, it will revert to the "original" speed.

EXAMPLE 1: <3C><02><08>

Change speed of port 2 to 9 600 bps

EXAMPLE 2: <3C><00><05>

Set speed of currently used port to 1 200 bps

Request Message Command (see A.6.19):

To request the speed setting, the following format is required:

	MSB	LSB	
MEC	17		
MEL	01..02		
MED	3C		Code of requested message
MED	00..FF		[Port number]. If 0 or none specified, then data for all installed ports will be packed into separate message elements inside the same frame. But if this is too long for a single frame, then the Error message 09: "not acceptable" will be generated.

A.6.17 Communications port configuration – Timeout /MEC 0x3D

Format: to set a timer to indicate loss of data at a communications port of an encoder.

Format:

	MSB	LSB	
MEC	3D		
MED	00..FF		0 = Current port 1 to 253 = Specific port 254 = All ports except current port 255 = All ports
MED	00..FF		00 No action 01 1 min 02 2 min : FE 254 min FF Timeout inactive

This command is provided to allow the encoder to take specific action on loss of the data link.

If a wrong or non-existent port number is specified, the encoder should respond with the Error message 06: "parameter out of range".

EXAMPLE 1: <3D><01><FF>

Disable timer associated with port 1.

EXAMPLE 2: <3D><00><01>

Set timer for currently used port to 1 min.

Request Message Command (see A.6.19):

To request the timeout setting, the following format is required:

	MSB	LSB	
MEC	17		
MEL	01..02		
MED	3D		Code of requested message
MED	00..FF		[Port number]. If 0 or none specified, then data for all installed ports will be packed into separate message elements inside the same frame. But if this is too long for a single frame, then the Error message 09: "not acceptable" will be generated.

A.6.18 Message acknowledgment / MEC 0x18

Function: to report acknowledgment of received messages.

Format:

	MSB	LSB	
MEC	18		
MED	00..FF		Response Code
MED	00..FF		Sequence counter number

The response code is as follows:

- 0 = Message correctly received
- 1 = CRC error has occurred: Message is wrong
- 2 = Message was not received (derived from the sequence counter)
- 3 = Message unknown
- 4 = DSN error
- 5 = PSN error
- 6 = Parameter out of range
- 7 = Message element length error
- 8 = Message field length error
- 9 = Message not acceptable
- 10 = End message (0xFF) missing
- 11 = Buffer overflow
- 12 = Bad stuffing, after 0xFD a number outside the range 00 to 02 has been received
- 13 = Unexpected end of message (0xFF) received
- 14 = Message correctly received, but not interpreted
- 15 = RFT frame number missing
- 16 – 255 = reserved for future use

The Sequence counter number is a copy of the sequence counter of the received message reflected by the response. This field is sent only if an error occurred; otherwise, if transmission is correct, this field is not transmitted. In this case, the response reflects to the last message (bi-directional communication mode used) or to all messages after last response (bi-directional communication mode used). If the sequence counter number cannot be determined due to errors, then 0x00 is used.

When multiple commands are sent in one message frame, the encoder may either return a frame containing one message acknowledgement for each command in the received frame, or a single acknowledgement if all commands in the frame were correctly received or the error is a global error related to the whole message frame.

This MEC can only be requested in bi-directional mode, requested response.

During the RDS2 RFT file data transfer to the RDS2 encoder (see MEC 0x57), the UECP frame number (2 bytes) is included. If one UECP frame number is missing or not received in consecutive order, it means that the data file was not correctly received.

In case of an RFT error being signalled with MEC 0x018, the RDS server shall resend the file from the first UECP frame. This enables the encoder to flush the reception buffer. The encoder shall return a message acknowledgment with code 15 specifying which frame number has not been received correctly.

EXAMPLE 1: <18><00>

In the bi-directional mode 1: All messages after the last response were correctly received. In the bi-directional mode 2: the last message was correctly received.

EXAMPLE 2: <18><02><42>

This means that sequence number 0x42 is wrong.

EXAMPLE 3: when with RDS2 the RFT protocol is used (see IEC 62106-2:2021, Annex C):

<18><15><02><33>

This means the RFT frame number 563 is not received.

A.6.19 Request message / MEC 0x17

Function: to request a specific message to be replied by the encoder.

Format:

	MSB	LSB	
MEC	17		
MEL	01..FD		
MED	00..FF		Code of requested message
MED	00..FF		[DSN] if required
MED	00..FF		[PSN] if required
MED	00..FF		Further information if required
	:		
	:		
MED	00..FF		Further information if required

The request message code is the code of a message to be answered, i.e. most message element codes can be requested, in the same format and length as defined.

The encoder may either respond with the requested message immediately or may respond with a message acknowledgement and then send the requested message for which the server may send a message acknowledgement.

The presence of DSN and PSN is dependent on the request message code and [DSN] and [PSN] are included in conformity with the code that is requested.

Request of the following MECs needs additional information:

- MEC 13 (AF) requires start location,
- MEC 14 (EON-AF) requires start location,
- MEC 29 (Group variant code sequence) requires group type and version,
- MEC 22 (RDS phase) requires reference table entry,
- MEC 0E (RDS level) requires reference table entry,
- MEC 0A (RT) requires the index of the RadioText in the RadioText buffers,
- MEC 3A (Access right) requires port number and the MEC concerned,
- MEC 3B (Port communication mode) requires port number,
- MEC 3C (Port baud rate configuration) requires port number,
- MEC 3D (Port timeout) requires port number.
- MEC 1A (Slow labelling codes) requires variant code

Details for the request message replies for each of these cases are given on the pages referring to these MECs.

MECs that cannot be requested are MEC 17 (request message) and MEC 2D (manufacturer's specific command).

EXAMPLE: <17><02><1A><01>

This means that the Request message code is 1A for DSN 0x01.

A.7 Manufacturers' and transmission operators' specific command / MEC 0x2D

Function: the content and meaning of this command is manufacturer- or transmission-operator-dependent.

Format:

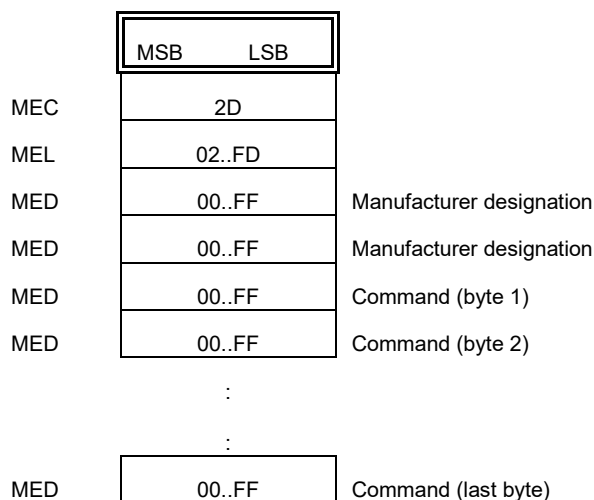

This command can be used by the manufacturer to implement any manufacturer-dependent special feature. The manufacturer designation consists of two bytes. The meaning of the command shall be specified by the manufacturer.

The Manufacturer / Transmission Operator codes are administered by the RDS Forum and published on the Internet:

[https://: www.rds.org.uk/](https://www.rds.org.uk/)

The procedure to register this kind of a code is explained in Annex D.

EXAMPLE: <2D><06><4D><41><12><34><56><78>

The manufacturer/operator "MA" sends a command having a length of 4 bytes comprising >12345678<.

A.8 Commands for the C-type groups used on data-streams 1 to 3

A.8.1 ODA-AID channel assignment for AS group type C (Alternative 1)/MEC 0x50

NOTE With Alternative 1, when MEC 0x50 is used and the ODA uses file data, AS group variants 0 to 7 are to be signalled together with the file data with MECs 0x57 and 58.

Function: to assign a channel number (0 to 63) to one or more ODAs using the assignment methods 1 to 4 in IEC 62106-2:2021 (Tables 3 and 4).

For ODAs using files with channels/pipes 0 to 15, this command shall only be used with assignment method 1 for the AS group variants 8 to 15, which do not belong to specific files.

For ODAs using files in channels/pipes 0 to 15, the respective file data shall be sent to the encoder with MEC 0x57 that carries in addition the information for the automatic generation by the encoder of AS group variants 0 and 1. If variants 2 to 7 are required, MEC 0x58 shall be used in addition to send the respective data to the encoder.

Format:

	MSB	LSB	
MEC	50		
MEL	03 or 09		Message length
MED	00..3F		Channel number (0..63)
MED	00..FF		Block 2 (AID – MSB)
MED	00..FF		Block 2 (AID – LSB)
MED	00..FF		Block 3 MSB
MED	00..FF		Block 3 LSB
MED	00..FF		Block 4 MSB
MED	00..FF		Block 4 LSB
MED	00..FF		AS group spacing (00=immediate)
MED	00..3F		Configuration

MEL Significance of the two control bits

- 03 Variant 0 and optional data is sent using MEC 0x57 and if AS group variant 2..7 data is needed it is sent to the encoder using MEC 0x58. In this case, MEC 0x50 inserts no AS groups
- 09 Encoder can insert this AS group with additional data for channels 16 to 63 and for channels/pipes 0::15 using a variant in the range 8..15

Bit 1 Bit 0 Buffer configuration

- | | | |
|---|---|--|
| 0 | 0 | Information transmitted once only and removed after transmission |
| 0 | 1 | Reserved |
| 1 | 0 | For cyclic transmission AS groups are added to the specific AS buffer |
| 1 | 1 | Remove all AS groups from the specific AS buffer (this means for channels in the range 0..15 all AS group variants in the range 8 to 15) |

Bit 2 Transmission method

- | | |
|---|------------------------------|
| 0 | Normal AS group transmission |
| 1 | Burst transmission |

Bit 3 Automatic AS group spacing

- | | |
|---|--|
| 0 | Use timing from AS group spacing parameter |
| 1 | Allow encoder to set optimal spacing of 10% assignment and 90% data groups |

Burst mode is only possible when the buffer configuration is not in the cyclic mode and for assignment method 1 only.

AS group spacing is entered in units of 5 groups (438 ms), e.g. spacing = 4 = 20 groups between consecutive AS groups. When a value of 00 is entered for spacing, the group will be transmitted immediately.

When a value of 00 is entered for spacing, the group will be transmitted immediately.

In a burst, the group is not repeated as in the burst definition of MEC0x54 but in a fixed, non-variable sequence of 4 times with a spacing of 2 other groups.

Bit 5	Bit 4	Assignment method (see IEC 62106-2)	Block 2	Block 3	Block 4
0	0	Method 1	AID1	Data1	Data2
0	1	Method 2	AID1	Data1	AID2
1	0	Method 3	AID1	AID2	Data2
1	1	Method 4	AID1	AID2	AID3

EXAMPLE: <50><09><3F><12><34><00><00><00><00><05><02>

Assign ODA with AID=1234 to channel 63 and repeat this AS group cyclically every 25 groups (2,2 s); method 1, no additional data.

A.8.2 ODA-AID channel assignment for AS group type C (Alternative 2) / MEC 0x51

NOTE With Alternative 2, when MEC 0x51 is used and the ODA uses file data, this is sent with MEC 0x55.

Function: to assign a channel number (0..63) to one or more ODAs using the assignment methods 1 to 4 from IEC 62106-2:2021 (Tables 3 and 4) and/or RFT file specific assignments as described in IEC 62106-2:2021, Annex C.

For channels/pipes 0..15 the assignment of ODAs using RFT file data, the configuration bit 6 shall be set to 1. All variant data may also be assigned when this mode has been chosen.

Format:

Regular assignments: Configuration byte, bit 6 = 0

	MSB	LSB	
MEC	51		
MEL	00..FF		Message length (NOTE 7)
MED	00..FF		AS group spacing
MED	10..3F		Channel number (16..63)
MED	00..7F		Configuration: bit 6 = 0: Regular assignment
MED	00..FF		Block 2 (AID- MSB)
MED	00..FF		Block 2 (AID – LSB)
MED	00..FF		Block 3 (MSB)
MED	00..FF		Block 3 (LSB)
MED	00..FF		Block 4 (MSB)
MED	00..FF		Block 4 (LSB)

NOTE 3 When less bytes are sent as defined in one of the methods 1..4, the encoder shall treat the content as being equal to 0.

Bit 1	Bit 0	Buffer configuration			
0	0	Information transmitted once only and removed after transmission			
0	1	Reserved			
1	0	For cyclic transmission, AS groups are added to the specific AS buffer			
1	1	Remove all AS groups from the specific AS buffer			
Bit 2	Transmission method				
0	Normal AS group transmission				
1	Burst transmission (in accordance with definition made in MEC0x54)				
Bit 3	Automatic AS group spacing				
0	Use timing from spacing parameter				
1	Allow encoder to set optimal spacing of 10% assignment and 90% data groups				
Bit 5	Bit 4	Assignment method (see IEC 62106-2)			
			Block 2	Block 3	Block 4
0	0	Method 1	AID1	Data1	Data2
0	1	Method 2	AID1	Data1	AID2
1	0	Method 3	AID1	AID2	Data2
1	1	Method 4	AID1	AID2	AID3
Bit 6	Assignment method				
0	ODA assignment without external files				
1	Assignment for ODAs using external files and RFT file assignments				

Spacing is entered in units of 5 groups (438 ms), e.g. spacing = 4 => 20 groups between consecutive AS groups. When a value of 0 is entered for spacing, the group will be transmitted immediately.

EXAMPLE: <51><05><05><3F><02><12><34>

Assign ODA with AID=1234 to channel 63 and repeat every 25 groups (2,2 s); method 1, no additional data.

For ODAs using data in the form of files which is transferred using the RFT protocol, the file specific assignments are made using this same assignment method while bit 6 of the configuration byte is set to 1 as shown in the next table.

Using this setting, a cluster of variants 0 to 7 may be defined, where variant 0 is mandatory. The cluster will be sent prior to the actual file transfer (using MEC 0x55) and also be repeated during the file transfer.

Format: RFT file assignments: Configuration byte, bit 6 = 1

	MSB	LSB	
MEC	51		
MEL	0A..22		Message length
MED	00..FF		AS group spacing
MED	00..FF		b6..b4: CRC mode (variant 1) b3.. b0: Channel/Pipe number 0..15)
MED	00..7F		<i>Configuration:</i> bit 6 = 1: RFT assignment
MED	00..FF		Block 2 (AID- MSB)
MED	00..FF		Block 2 (AID – LSB)
MED	00..FF		Block 3 Variant 0 (MSB)
MED	00..FF		Block 3 Variant 0 (LSB)
MED	00..FF		Block 4 Variant 0 (MSB)
MED	00..FF		Block 4 Variant 0 (LSB)
MED	00..FF		Block 3 Variant 2..15 (MSB)
MED	00..FF		Block 3 Variant 2..15 (LSB)
MED	00..FF		Block 4 Variant 2..15 (MSB)
MED	00..FF		Block 4 Variant 2..15 (LSB)

Bit 1	Bit 0	Buffer configuration
0	0	Information transmitted once only and removed after transmission
0	1	Reserved
1	0	For cyclic transmission; AS groups are added to the specific AS buffer
1	1	Remove all AS groups from the specific AS buffer

Bit 2	Transmission method
0	Normal AS group transmission
1	Burst transmission (in accordance with definition made in MEC0x54)

Bit 5	Bit 4	Bit 3	Memory management (all related to current AID)
0	0	0	Add this file definition to the buffer
0	0	1	Flush all files and their variants 0 to 7
0	1	0	Flush variants 8 to 15
0	1	1	Flush this file ID and this version and its variants 0 to 7
1	0	0	Flush this file ID and all its versions and its variants 0 to 7
1	0	1	Reserved
1	1	0	Reserved
1	1	1	Reserved

Bit 6 Assignment method

- 0 ODA assignment without external files
- 1 Assignment for ODAs using external files and RFT file assignments

EXAMPLE: <51><09><05><00><42><12><34><00><00><04><00>

Assign ODA, using RFT with AID=1234 to channel/pipe 0 and repeat assignment every 25 groups (2,2 s), no additional variants in the range 2..7, file version and ID = 0 and size is 1 kB, no CRC required.

A.8.3 Relative priority group sequence / MEC 0x53

Function: to set the relative priority level for groups transmitted using the ODA with "immediate" priority (MEC 0x56). This permits the alteration of the relative priority of groups.

Format:

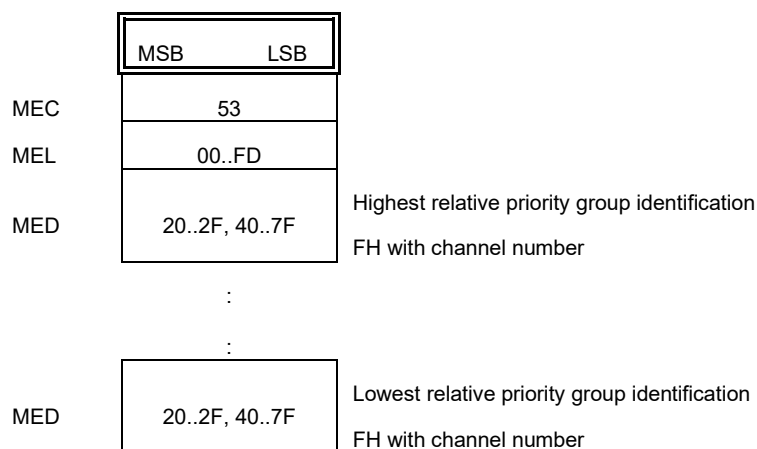

The function header FH is used to signal the groups using the codes below

Function header FH								
b7	b6	b5	b4	b3	b2	b1	b0	
0	0	1	0	y	y	y	y	b3-b0 is the pipe number from 0 to 15
0	1	c	c	c	c	c	c	Group type C channel number

EXAMPLE: <53><04><7F><4E><79><29>

Group type C channel 63 has a higher priority than group type C channel 14, which has a higher priority than group type C channel 57, which has a higher priority than pipe 9.

A.8.4 Burst mode control for ODA group type C / MEC 0x54

Function: to control the burst insertion of a C-type ODA group. The possibility to enable this burst mode transmission exists in MECs 0x51 and 56.

Format:

	MSB	LSB	
MEC	54		
MED	00..FF		AID (MSB)
MED	00..FF		AID (LSB)
MED	00..FF		Bits 7 .. 4: Number of repetitions (0 ..15)
			Bits 3 .. 0: Spacing (0..15)

The number of repetitions is indicated in the range 0 to F. Spacing is indicated by the minimum number of other groups between two ODA groups of this same application group.

EXAMPLE: <54><12><34><50>

ODA groups with AID 0x1234 will be transmitted 5 times with no groups in between.

A.8.5 RFT file data transfer (Alternative 2)/MEC 0x55

NOTE Users of Alternative 1 are to use MEC 0x57 instead.

Function: to send a file to the encoder. The RDS2 transfer groups will have to be generated by the encoder, in accordance with the RDS2 file transfer protocol RFT, see IEC 62106-2. Before sending RFT file data, all file-related variants 2..7 shall have been sent using MEC 0x51. (Variant 0 is implicitly defined in this MEC 0x55, but may also be predefined in MEC 0x51 together with other file related variants 2 to 7).

Format:

	MSB	LSB	
MEC	55		
MEL	0A..FE		MEC length
MED	00..FF		AID MSB
MED	00..FF		AID LSB
MED	00..FF		b7..b6 Repeat style
MED	00..FF		b5..b0 File ID
MED	00..FF		b7..b6 Repeat count
			b4..b2 File version
			b1..b0 Total number of frames MSB(its)
MED	00..FF		Total number of frames LSB(its)
MED	00..FF		b7 CRC flag
			b6..b2 reserved for future use
MED	00..FF		b1..b0 Frame number MSB(its)
MED	00..FF		Frame number LSB
MED	00..FF		First byte of the file
MED	00..FF		Second byte of the file
MED	:		
MED	00..FF		Last byte of the file

The file to be transmitted is split into N UECP frames of 246 bytes. The file size is limited to 163 833 bytes. 246 is the remaining number of bytes considering the maximum number of bytes (255) available in a UECP message field.

A file for an ODA application is identified with a file ID (6 bits) and a file version (3 bits). If the file id and/or file version for a dedicated AID is different from the one in the encoder's receiving memory, then this implies a new file is being transmitted and the RFT toggle bit shall have to be toggled by the encoder.

To optimize file reception, two parameters are added to control the transmission method:

Bit 7	Bit 6	Repeat style function (MED 3)
0	0	Default (no special repeats)
0	1	Repeat on group level
1	0	Repeat on CRC block level
1	1	Reserved

Usually, a file will be sent several times in succession. Missing an RDS group or receiving a damaged group means the receiver shall wait until the entire file has been sent before the specific group can be received again. In practice it might seem useful to repeat sections of the file (e.g. the size of the CRC chunks) or even on group level. Experience with this functionality will reveal the best option to follow.

The repeat count parameter allows setting of the number of times a file or special block or group shall be repeated. In default mode, the file will be repeated "forever" or until a new file for the same AID is sent.

Bit 7	Bit 6	Repeat count (MED 4)
0	0	Default (no special repeats)
0	1	Repeat 2 times
1	0	Repeat 3 times
1	1	Repeat 4 times

A.8.6 ODA data group command / MEC 0x56

Function: to transmit ODA-AID data for upper streams (to group type C channel buffers)

Format:

	MSB	LSB	
MEC	56		
MED	00..FF		AID MSB
MED	00..FF		AID LSB
MED	00..03		Configuration: Bits 7 to 6: Set to 0 Bits 5 to 4: Priority settings Bits 3 to 2: Mode selection Bits 1 to 0: Buffer configuration
MED	00..FF		ODA data, block 1 LSB
MED	00..FF		ODA data, block 2 MSB
MED	00..FF		ODA data, block 2 LSB
MED	00..FF		ODA data, block 3 MSB
MED	00..FF		ODA data, block 3 LSB
MED	00..FF		ODA data, block 4 MSB
MED	00..FF		ODA data, block 4 LSB

Configuration bits are coded as follows:

Bit 1	Bit 0	Buffer configuration
0	0	Information transmitted once only and removed after transmission
0	1	Reserved
1	0	For cyclic transmission; ODA data sets are added to the specific buffer
1	1	Remove all ODA information from the specific ODA buffer
Bit 3	Bit 2	Mode selection
0	0	Normal mode
0	1	Burst mode (see MEC 0x54)
1	0	Reserved
1	1	Reserved
Bit 5	Bit 4	Priority setting
0	0	Normal
0	1	Extremely urgent – valid only if buffer configuration = 0
1	0	Immediate – valid only if buffer configuration = 0
1	1	Reserved

A group sent with "Extremely urgent" priority will be inserted as soon as possible in accordance with the group sequence.

A group with "Immediate" priority will be transmitted immediately, irrespective of the group sequence, but respecting the priorities defined in IEC 62106-2.

EXAMPLE: <56><AB><CD><00><1F><64>><73><82><91>><31><23>

Transmit once only in the group type C group ODA channel assigned to ODA-AID 0xABCD the ODA data >0x1F, 0x6473, 0x8291, 0x3123< in normal mode and with normal priority.

A.8.7 RFT file data transfer and associated data for the assignment group(s) variants 0 and 1 (Alternative 1) / MEC 0x57

NOTE Users of Alternative 2 are to use MEC 0x55 instead.

Function: to send the data for a file to the encoder and to define the data for AS group variant 0 and indicate if AS group variants 1 to 7 are needed for this file. The RFT transfer groups and the AS group variants 0 and 1 will have to be generated by the encoder, in accordance with the RDS2 file transfer protocol RFT using this data, see IEC 62106-2. If AS group variants 2..7 are needed, their data is defined with MEC 0x58. The AID channel assignment shall always be made first with MEC 0x50.

Format:

		MSB LSB	
MEC		57	
	MEL	03..FD	MEC length
MED	MED	00..FF	AID MSB
MED	MED	00..FF	AID LSB
MED			b7 .. b2 File ID
	MED	00..FF	b1 .. b0 Configuration
MED	MED	00..0F	b3 .. b1 File version
			b0 CRC flag
	MED	00..FF	AS group spacing
MED	MED	00..F2	b7..b5 CRC mode (only if CRC is required)
			b4: More variants in range 2 to 7 required: 1=yes 0=no, if "1" MEC 58 is required
			b3..b0 Total number of frames MSB
MED	MED	00..FF	Total number of frames LSB
	MED	00..02	Frame number MSB
	MED	00..FF	Frame number LSB
	MED	00..FF	First byte of the file
	MED	00..FF	Second byte of the file
	MED	:	
	MED	00..FF	n th byte of the file

Conventions:

In this MEC 0x57, the AS group spacing is entered in units of 5 groups (438 ms), e.g. if spacing equals 4, this means 20 groups in between consecutive AS groups of the same variant. This AS group spacing is also valid for MEC 0x58. It is the spacing between AS groups carrying the same variant number in the range 0 and 2..7. AS group variants 2..7 are always sequentially inserted immediately after variant 0 in an increasing order of the variant number.

A file for an ODA application is identified with a file ID and a file version. The file size is limited to 163 833 bytes.

For variant 0, the encoder determines the file size parameter from the number of bytes being transferred for the file.

244 is the remaining number of bytes considering the maximum number of bytes (255) available for a message inside a UECP frame.

The file to be transmitted is split into N UECP frames with a maximum of 244 bytes of file data for the message in each frame. The total number of UECP frames required to transfer the file is transmitted in addition to the current UECP frame number.

Variant 0 is based on mandatory information that shall be used to automatically generate it by the encoder.

File ID, file version and toggle bit:

A file for an ODA application is identified with a file ID (6 bits) and a file version (3 bits). If the file ID and/or file version for a dedicated AID is different from the one in the encoder's memory, then this implies a new file shall be transmitted and the RFT toggle bit shall be changed by the encoder.

Encoder buffer configuration management:

Two configuration bits are used to manage the encoder's memory or buffers:

Bit 1	Bit 0	Buffer configuration
0	0	Add this file (ID + version) in the memory / buffer list for that AID
0	1	Flush all files (IDs) for that AID
1	0	Flush only this file (ID + version) for that AID
1	1	Reserved

CRC flag:

- When this flag is on (1), the encoder shall generate and transmit a CRC in conformity with the selection made in the CRC-mode (IEC 62106-2:2021, Annex C).
- Variant 1 shall have priority over all other variants 0 and 2 to 15 as it gives the CRC for the file data chunk just transmitted.
- It shall be inserted by the encoder immediately after the file data chunk to which the CRC belongs.

The variant 0 and 2 to 7 AS group spacing is defined in MEC 0x57. The variant 8 to 15 group spacing is defined in MEC 0x50.

If an automatic insertion conflict arises with the required AS group variants in the range 0 and 2 to 15, then all required variants shall be transmitted in sequence and in ascending order.

A.8.8 File associated data for AS group variants 2 to 7 (Alternative 1)/MEC 0x58

NOTE Users of Alternative 2 are to use MEC 0x51 instead.

Function: to send data for AS group variants 2 to 7. The encoder will sequence the corresponding method 1 assignment groups in ascending order and in the time window during which the file is sent to which these variants belong (same file ID and same version number and the toggle bit kept unchanged). The insertion follows immediately variant 0. In this way, the same AS group spacing as defined in MEC 0x57 is used.

Format:

	MSB ... LSB	
MEC	58	
MEL	04..FC	
MED	00..FF	AID MSB
MED	00..FF	AID LSB
MED	00..FF	b7..b6: reserved for future use b5..b0 : File id
MED	00..FF	b7..b5 : File version b4..b2 : reserved for future use b1 ..b0 Encoder's buffer configuration management
MED	00..FF	b7:0, b6..b4: First Variant code (c15..c12, block 3) b3 ..b0: First variant code data (c11..c8, block 3)
MED	00..FF	First variant code data (c7..c0, block 3)
MED	00..FF	First variant code data (d15..d8, block 4)
MED	00..FF	First variant code data (d7..d0, block 4)
MED	00..FF	b7:0, b6 ..b4: Second variant code (c15..c12, block 3) b3 ..b0: Second variant code data (c11..c8, block 3)
MED	00..FF	Second variant code data (c7..c0, block 3)
MED	00..FF	Second variant code data (d15..d8, block 4)
	00..FF	Second variant code data (d7..d0, block 4)
	...	
MED	00..FF	b7:0, b6 .. b4: n th variant code (c15..c12, block 3)
MED	00..FF	b3 ..b0: MSB 'th variant code data (c11..c8, block 3)
MED	00..FF	n th variant code data (c7..c0, block 3)
MED	00..FF	n th variant code data (d15..d8, block 4)
MED	00..FF	LSB n th variant code data d7..d0, block 4)

Conventions: assignment and associated data of the AS groups using variants 2 to 7 shall be received by the encoder before starting the transmission process of the file data.

Encoder buffer configuration management:

Two bits are used to manage the encoder's memory.

Bit 1	Bit 0	Buffer configuration
0	0	Add all variants for that file (AID + file ID + version)
0	1	Flush all variants for that file (AID + file ID + version)
1	0	Flush only this variant code for that file (AID + file ID+ version)
1	1	Flush all variants in the range 2 to 7 for that AID

Usage:

Assignment groups with file-related variants 2 to 7 shall be automatically inserted in ascending order, just like variant 0 during the time window used for sending the file to which they belong, i.e. within the time-interval during which the respective file is transmitted with RFT groups and the respective toggle bit in the RFT groups remains unchanged.

When variants 2 to 7 are defined, the encoder starts to transmit those variants prior to starting the file data transmission using the RFT protocol. Variants 0 and 2 to 7 are transmitted cyclically during the whole file transmission time, starting with the mandatory variant 0 followed by the lowest variant code associated to the same file ID and file version, etc.

EXAMPLE: <58><0C><FF><7F><01><00><21><23><45><67><78><9A><BC><DE>

AID FF7F

File ID = 1

File version= 0

Configuration = 0, add variant list for that file (AID + file ID + file version)

Variant code 2 data = 1234567

Variant code 7 data = 89ABCDE

When file ID 01 and file with version 00 are transmitted, the encoder sends first consecutively AS group variant 0 followed by AS groups with variants 2 and 7:

Block 1	Block 2	Block 3	Block 4
10000000 0000yyyy	FF7F	Variant 2 code and data 123: 2123	Variant 2 data: 4567
10000000 0000yyyy	FF7F	Variant 7 code and data 89A: 789A	Variant 7 data: BCDE

A.8.9 Define in the RFT a file sequence for the AID/MEC 0x59

Function: to set the file sequence for the AID.

Format:

	MSB	LSB
MEC	59	
MEL	03..FD	
MED	00..FF	AID MSB
MED	00..FF	AID LSB
MED	00..7D	Number of the file IDs in the list
MED	00..0F	b7..b6 = 0
		b5..b0 = File ID
MED	00..07	b7..b3 = 0
		b2..b0 = File version
...		
MED	00..0F	b7..b6 = 0
		b5..b0 = File ID
MED	00..07	b7..b3 = 0
		b2..b0 = File version

Number of file IDs in the list = 0x00 means that there is no defined sequence. All following file IDs and file versions are transmitted sequentially one after the other.

If a file sequence is defined, it is necessary to declare the number file IDs that are used in the list.

EXAMPLE 1: <59><07><33><50><02><01><01><02><03>

Set the file sequence for the 2 file IDs for AID 3350 to file ID 1 + version 1, file ID 2 + version 3.

EXAMPLE 2: <59><09><44><00><03><01><01><01><01><<02><03>

Set the file sequence for the 3 file IDs for AID 4400 to file ID 1 + version 1, file ID 1 + version 1, file ID 2 + version 3.

A.8.10 Define the group sequence / MEC 0x61

Function: to set the group sequence for the upper streams in the specified data set(s). AS groups are not allowed in this group sequence definition.

Format:

		MSB	LSB		
MEC		61			
DSN		00..FF		00: Current DSN	
MEL		02..FC			
MED		00..03		Bits 1 ..0: Upper stream number configuration	
MED		00..7F		Group ID	
		...			
MED		00..7F		n th Group ID	

Stream number configuration is used to link the group sequence with data-stream 1 to 3 using the following values:

Bit 1	Bit 0	Group sequence
0	0	Group sequence is for all three upper data-streams
0	1	Group sequence is for the upper data-stream 1 only
1	0	Group sequence is for the upper data-stream 2 only
1	1	Group sequence is for the upper data-stream 3 only

The Group ID is used to signal the group using the codes below:

Group ID								
b7	b6	b5	b4	b3	b2	b1	b0	
0	0	0	a	a	a	a	b	Legacy mode, exactly as MEC 16 group type coding: b4..b1 is the group type number from 0 to 15 and 'b0' is group version
0	0	1	0	y	y	y	y	b3..b0 is the pipe number from 0 to 15
0	1	c	c	c	c	c	c	Group Type C where b5..b0 is the ODA channel number, from 0 to 63

Example: <61><00><08><01><20><21><22><04><10><77><7F>

Set in the current data set a new group sequence for the data-stream 1 comprising pipes 0, 1 and 2, legacy groups 2A and 8A and channels 55 and 63.

A.8.11 Extended group sequence for group type C/MEC 0x83

Function: to set alternative group sequences for use when dynamic buffers have no more data for particular groups.

Format:

		MSB	LSB		
MEC		83			
DSN		00..FF			
MEL		02..FC			
MED		00..03		Bits 1..0: Upper data-stream number configuration	
MED		02..1F		Number of alternatives	
MED		00..1F		Alternative 1	
	:				
	:				
MED		00..1F		Alternative n	

The upper data-stream number configuration is used to link the group sequence using the following values:

Bit 1	Bit 0	Extended group sequence configuration
0	0	Extended group sequence is for all three upper data-streams
0	1	Extended group sequence is for the upper data-stream 1 only
1	0	Extended group sequence is for the upper data-stream 2 only
1	1	Extended group sequence is for the upper data-stream 3 only

The group identification field is used to signal the group using the codes below:

Group ID								
b7	b6	b5	b4	b3	b2	b1	b0	
0	0	0	a	a	a	a	b	Legacy mode, exactly as MEC 16 group type coding: b4..b1 is the group type number from 0 to 15 and 'b0' is group version
0	0	1	0	y	y	y	y	b3..b0 is the pipe number from 0 to 15
0	1	c	c	c	c	c	c	Group Type C Where b5..b0 is the ODA channel number, from 0 to 63

More than one alternative sequence is allowed for the same group type, the list of these alternative sequences being cycled through when there is no data for the replaced group. In the case where there are several alternative sequences for the same group type, the position in the list is not advanced if data is available for the particular group type.

EXAMPLE: <83><00><0F><02><0E><03><10><0C><43><0E><02><43><47><0E><03>
<10><0C><43>

For the current DSN, data-stream 2 only, transmission of the first type 7A group shall be replaced, if there is no data, by transmission of a type 8A group or, if the type 8A group buffer is empty, by a type 6A group or, if the type 6a group buffer is empty, by a type 3C group. The next transmission of a type 7A group for which there is no data, should be replaced by a transmission of a type 3C group or, if the type 3C buffer is empty, by a 7C group. The following transmission of a type 7A group for which there is no data, should be replaced by the alternative sequence of group type 8A, 6A, 3C.

0A,	2A,	7A,	14A,	7A,	0A,	6A,	2A,	7A,	group
									sequence
		8A		3C				8A	first alternate
		6A		7C				6A	second alternate
								3C	final alternate

A.8.12 Upper data-stream level / MEC 0xE0

Function: to adjust the level of the upper data-stream subcarriers 1 mV_{p-p} to 3 in mV_{p-p} for a specified reference table entry.

Format:

	MSB	LSB	
MEC	E0		
MED	00..03		Bits 1..0: Upper data-stream number configuration
MED	00..FF		Bits 7..5: Reference table entry Bits 4...0: RDS level MSB
MED	00..FF		RDS level LSB

Bit 1	Bit 0	Stream selection
0	0	For all three upper data-streams
0	1	For upper data-stream 1 only
1	0	For upper data-stream 2 only
1	1	For upper data-stream 3 only

Reference "0" means that the level is related to all table entries, "1" to "6 " identify a specific table entry, "7" is the currently selected table entry. The RDS level is expressed in the range from 0 mV_{p-p} to 8 191 mV_{p-p} and converted to a 13-bit number.

EXAMPLE: <E0><00><21><D2>

Set the RDS level to 466 mV_{p-p} for reference table entry, input 1 for all upper data-streams.

A.8.13 Upper data-streams on – off/MEC 0xE1

Function: to switch the upper streams on/off

Format:

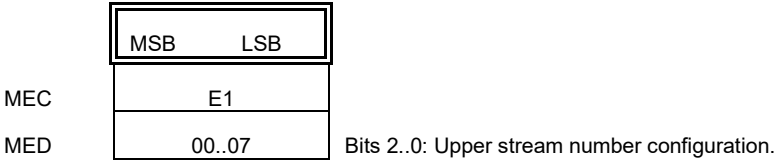

- Bit 0** Upper data-stream number 1: 1=on, 0=off
- Bit 1** Upper data-stream number 2: 1=on, 0=off
- Bit 2** Upper data-stream number 3: 1=on, 0=off

Example: <E1><02>

means switch the upper data-stream 2 output signal "ON"; data-streams 1 and 3 are switched "OFF".

Annex B (normative)

UECP transmission over IP networks

The UECP shall be transported over IP by using either UDP or TCP datagrams in the following way:

- One IP packet contains exactly one UECP packet.
- The length of the IP packets is variable; the length of the IP payload is equal to the length of the transported UECP packet (including STA and STP).
- The first character of the IP payload in all IP packets is always the UECP 'Start' character (STA, 0xFE).
- The last character of the IP payload in all IP packets is always the UECP 'Stop' character (STP, 0xFF).
- UECP packets are always transmitted 'stuffed' (see 8.2.3).
- An IP packed UECP stream will always be sent to a previously defined IP port. In case a device accepts several UECP streams, e.g., if several audio signals are present, the differentiation is done by sending the IP packets to different IP ports. Port numbers should be in the range from 49 152 to 65 535 (private/dynamic ports). If acceptable by network administration, ports in the range from 1 024 to 49 151 (registered ports) can be used. Generally, the existence of firewalls and their permeability for packets with the selected port numbers shall be taken into account.

Annex C (informative)

Transport of UECP data within DVB-S radio

For DVB-S radio, the transmission of RDS data is specified by ETSI [9, 10]. The UECP is used as transport protocol. The UECP data-frames are transmitted in the ancillary data field of the MPEG audio frames of the associated audio channel. The presence of UECP data-frames is signalled by the ancillary data identifier, bit 6. If UECP data-frames are present, this bit is set to "1".

Commercial DVB-S encoders and receivers exist on the market to insert UECP data-frames into DVB-S radio streams and to extract them after DVB-S radio signal reception. The transmission technique is occasionally used by service providers to supply any of their terrestrial transmitter networks with the respective UECP data.

NOTE Refer to the relevant ETSI guidelines for DVB-S radio Service Information (SI) [11].

Annex D (informative)

Manufacturer and transmission operator command code registration

This specific command, MEC 2D, is specified in Clause A.7. The RDS Forum (RDS Registration Office at the address shown on the RDS Forum web site at URL <https://www.rds.org.uk/>) maintains a list of manufacturer and transmission operator codes, published in the UECP section of this website.

Registration of a relevant code can be obtained from the RDS Forum against payment of the corresponding administrative fee.

Annex E (informative)

Listing of Message Element Codes

MEC	UECP message name
0x01	PI
0x02	PS
0x03	TP – TA
0x04	DI – PTYI
0x07	PTY
0x09	Real time clock correction for CT
0x0A	RT
0x0B	PSN enable / disable
0x0D	Real time clock for CT
0x0E	RDS level
0x13	AF
0x14	EON-AF
0x15	EON-TA control
0x16	Group sequence for data-stream 0
0x17	Request message
0x18	Message acknowledgement
0x19	CT on-off command
0x1A	ECC and other slow label settings
0x1C	Data set select
0x1D	Reference input selection
0x1E	RDS on-off command for subcarrier 0
0x21	LPS
0x22	RDS phase for subcarrier 0
0x23	Site address
0x24	Free format data group for data-stream 0
0x26	TDC
0x27	Encoder address
0x28	Make PSN list
0x29	Group variant code sequence for data-stream 0
0x2A	TA control
0x2B	EWS
0x2C	Communication mode
0x2D	Message name Manufacturer – Transmission operator specific command
0x2E	Linkage information
0x30	TMC
0x38	Extended group sequence for data-stream 0
0x3A	Encoder access right
0x3B	Communication port configuration – Mode
0x3C	Communication port configuration – Speed

MEC	UECP message name
0x3D	Communication port configuration – Time out
0x3E	PTYN
0x3F	EON enable / disable
0x40	ODA configuration and Short message command for group types A and B
0x41	ODA assignment group usage sequence for group types A and B
0x42	Old ODA data group for group types A and B replaced by MEC 0x046
0x43	ODA relative priority group sequence for group types A and B
0x44	ODA data group repetitions and burst mode
0x45	ODA Spinning wheel timing control
0x46	ODA data
0x47	ODA data command access right
0x48	DAB Dynamic label command
0x50	ODA-AID channel assignment for AS group type C (Alternative 1)
0x51	ODA-AID channel assignment for AS group type C (Alternative 2)
0x53	Relative priority group sequence for group type C
0x54	Burst mode control for ODA group type C
0x55	File associated data for Alternative 2
0x56	ODA data group command for group type C
0x57	RFT file data transfer and associated data in variants 0 and 1 of the assignment group(s) for Alternative 1
0x58	File associated data for variants 2 to 7 for Alternative 1
0x59	File sequence for AID in RFT
0x61	Group sequence for group type C
0x83	Extended group sequence for group type C
0xAA	DAB Dynamic label message
0xE0	Upper stream level
0xE1	Upper streams on – off

Annex F (informative)

Special optional ODA transmission mode on RDS data-stream 0 with group type A or B

F.1 "Burst mode" transmission

This mode enables on data-stream 0 ODA data groups of group type A or B to be transmitted like 14B and 15B groups with a predetermined number of repetitions and inter-group spacing.

F.2 "Spinning wheel" mode transmission

The spinning wheel technique is based on the following ideas (see Figure F.1):

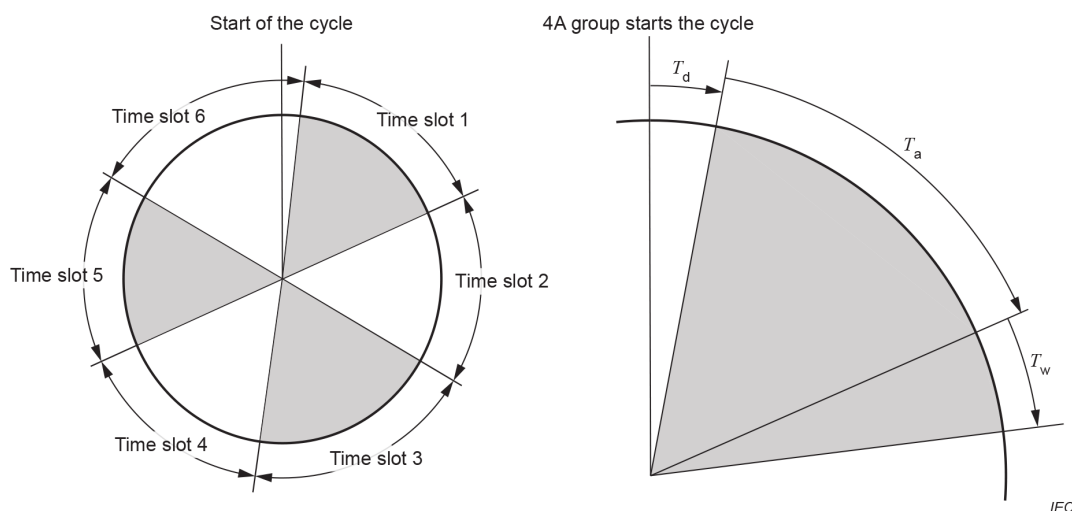

Figure F.1 – "Spinning wheel" mode – one minute transmission cycle that starts with a 4A group

The "Spinning wheel" mode works as follows:

- Divide the minute into an integer number of time slots.
- Split each of these time slots into a first part (activity time, T_a), during which ODA groups may be inserted into the data-stream and a second part (window time, T_w), during which no ODA groups shall be inserted into the data-stream.
- Between the start of the minute (as indicated in the RDS-data-stream by the presence of the type 4A group, which shall be transmitted for this technique) and the start of the first time slot, a delay is possible (delay time, T_d).

The meaning of the parameters T_a , T_d and T_w is illustrated above.

The insertion of ODA-groups is governed by the following rules:

- No ODA groups should start outside the activity window.
- An ODA group may be completed outside the activity time.
- T_a , T_w , T_d have to be multiples of a second, with $60 \text{ s} / (T_a + T_w) = n$ (where n : integer > 0).

The actual values of these parameters should be assumed to be either default values or be coded into the system information.

Annex G (normative)

Message Element Codes kept for backwards compatibility on data-stream 0

G.1 General

The following MECs are still being used by some transmission operators. For reasons of backwards compatibility, they are listed here. However, for the use of the current RDS standard, the IEC 62106 series, these MECs are no longer required.

G.2 ODA data group/MEC 0x42

Function: to add a group to the data buffer for that application group type code.

Format:

	MSB	LSB	
MEC	42		
MED	07..1B		Application group type code (see IEC 62106-2 for valid codes)
MED	00..7F		Configuration: Bits 7..6: Set to 0 Bits 5 to 4: Priority setting (see 8.6) Bits 3..2: Mode selection Bits 1..0: Buffer configuration
MED	00..1F		Block 2, 5 bits
MED	00..FF		Block 3 MSB
MED	00..FF		Block 3 LSB
MED	00..FF		Block 4 MSB
MED	00..FF		Block 4 LSB

Bit 1	Bit 0	Buffer configuration
0	0	Information transmitted once only and removed after transmission
0	1	Reserved
1	0	For cyclic transmission, data information sets are added to the specified buffer
1	1	Remove all data information sets from the specified data buffer

Bits 3 and 2 of the second MED are coded as follows:

Bit 3	Bit 2	Mode selection
0	0	Normal mode
0	1	"Burst mode" (see MEC 44)
1	0	"Spinning wheel mode" (see MEC 45)
1	1	Reserved

Bits 5 and 4 of the second MED are coded as follows:

Bit 5	Bit 4	Priority setting (see 8.6)
0	0	Normal
0	1	"Extremely urgent"; valid only if the buffer configuration is 00
1	0	Immediate
1	1	Reserved

Bits 6 and 7 of the second MED are set to zero.

A group sent with "Extremely urgent" priority will be inserted as soon as possible in accordance with the group sequence.

A group with "immediate" priority will be transmitted immediately, irrespective of group sequence, but respecting the priorities defined in IEC 62106-2, unless the ODA priority group sequence has been configured (see 8.6).

EXAMPLE: <42><16><14><12><34><56><78><90>

Data for ODA application group type code 11A, block 2 data is 0x12, block 3 data is 0x3456 and block 4 data is 0x7890. The data is transmitted once only in burst mode (defined by the ODA control command MEC 44), with high priority.

G.3 EWS / MEC 0x2B

Function: to send the emergency warning system data (37 bit) in type 9A group.

Format:

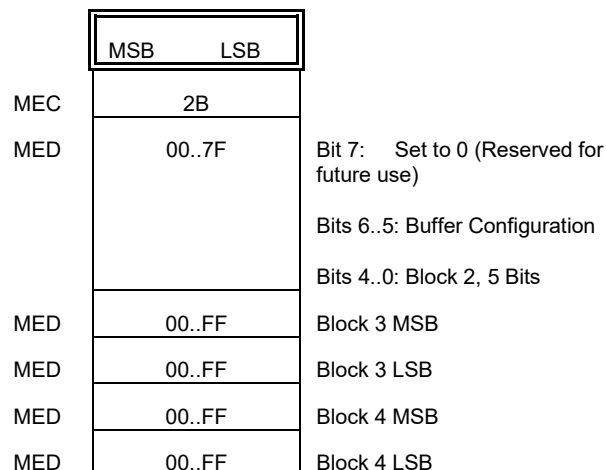

37 bits of EWS data is to be sent to the encoder EWS buffer.

Bits 6 and 5 of the first Message Element Data are coded as follows:

Bit 6	Bit 5	Buffer configuration
0	0	Information transmitted once only and removed after transmission
0	1	Reserved
1	0	For cyclic transmission, EWS information sets (37 bit) are added to the buffer
1	1	Remove all EWS information sets (37 bit) from the EWS buffer

EXAMPLE: <2B><41><23><45><67><89>

Add the 37 bits of EWS data >0x01 2345 6789< for type 9A group to the EWS buffer. Transmit the contents of the buffer including this new information cyclically.

G.4 TDC/MEC 0x26

Function: to send the transparent data channel data (37 bits).

Format:

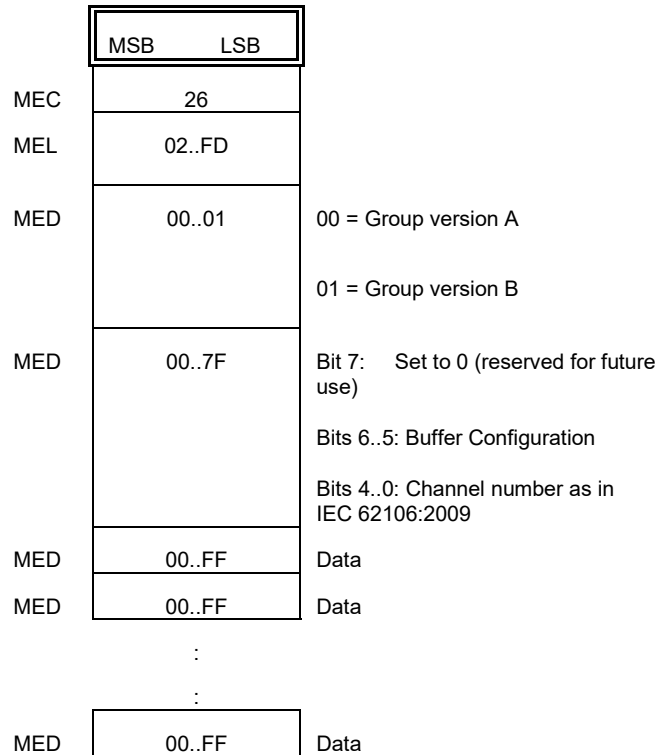

The data in the command is sent together with the given binary coded channel number.

The data shall be provided in multiples of 4 bytes for A groups and 2 bytes for B groups.

Bits 6 and 5 of the second MED are coded as follows:

Bit 6	Bit 5	Buffer configuration
0	0	Information transmitted once only and removed after transmission
0	1	Remove the TDC data sets from the specified TDC channel of the TDC buffer
1	0	For cyclic transmission, TDC data sets are added to the specified TDC buffer
1	1	Remove all TDC information sets from the specified TDC buffer

EXAMPLE: <26><05><00><01><45><42><55>

Send the data >EBU< on TDC channel 1, once only.

G.5 TMC / MEC 0x30

It is recommended in ISO TS 14919 [8] that TMC be transmitted in ODA using type 8A/3A groups. Therefore, ODA commands should be used instead. The command is being kept only for backwards compatibility reasons.

Function: to edit the TMC data in group type 8A.

Format:

	MSB	LSB	
MEC	30		
MEL	01..FB		
MED	00..FF		Bit 7: 0= Normal, 1= "Extremely urgent"
			Bits 6..5: Buffer configuration
			Bits 4..1: Number of transmissions 1-15
			Bit 0: Set to zero
MED	00..1F		Block 2: 5 bits of first TMC message
MED	00..FF		Block 3: MSB of first TMC message
MED	00..FF		Block 3: LSB of first TMC message
MED	00..FF		Block 4: MSB of first TMC message
MED	00..FF		Block 4: LSB of first TMC message
	::		
MED	00..FF		Block 4 LSB of n th TMC message

Multiples of 37 bits of TMC data are to be sent to the encoder's internal TMC buffer.

Bits 6 and 5 of the second MED are coded as follows:

Bit 6	Bit 5	Buffer configuration
0	0	Information transmitted with the number of transmissions specified and removed after completion
0	1	Reserved
1	0	For cyclic transmission, TMC information sets (37 bits) are added to the TMC buffer
1	1	Remove all TMC information sets from the TMC buffer

EXAMPLE: <30><0B><04><01><23><65><B0><E3><11><23><45><67><89>

Add the TMC data, >0x01 2365 B0E3< and >0x11 2345 6789< with normal priority to the TMC buffer. Transmit each information set twice.

G.6 DAB Dynamic label message – DL/MEC 0xAA

Function: to transmit Dynamic Label (DL) message data for DAB.

Format:

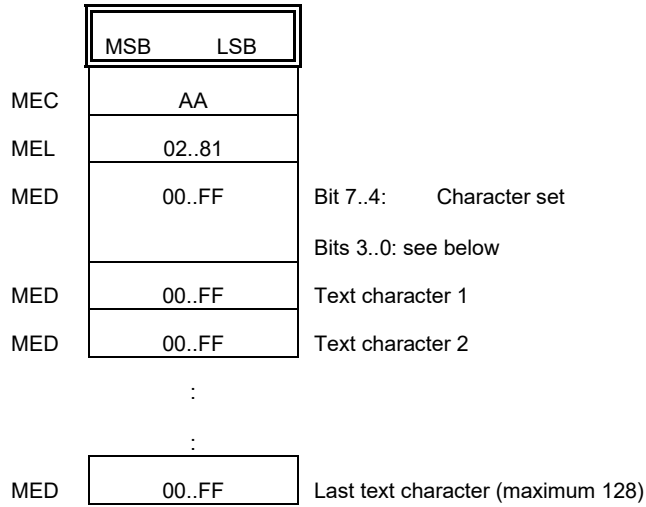

Coding of Dynamic Label message data is in accordance with ETSI 300 401.

- Bits 7 to 4** Character set as defined in ETSI TS 101 756
- Bits 3 to 0** These bits shall be set as defined in ETSI EN 300 401

(Figure 44 "Structure of the X-PAD data group for each DL segment": reserved for future use bits of field 2: bits 6..4)

EXAMPLE: <AA><12><00><44><41><42><20><44><79><6E><61><6D><69><63><20><4C><61><62><65><6C>

This DL message carries the text >DAB Dynamic Label<

NOTE DAB uses its own character coding table. It is not the same as the one used for RDS.

G.7 DAB Dynamic label command/MEC 0x48

Function: to transmit Dynamic Label (DL) command data for DAB.

Format:

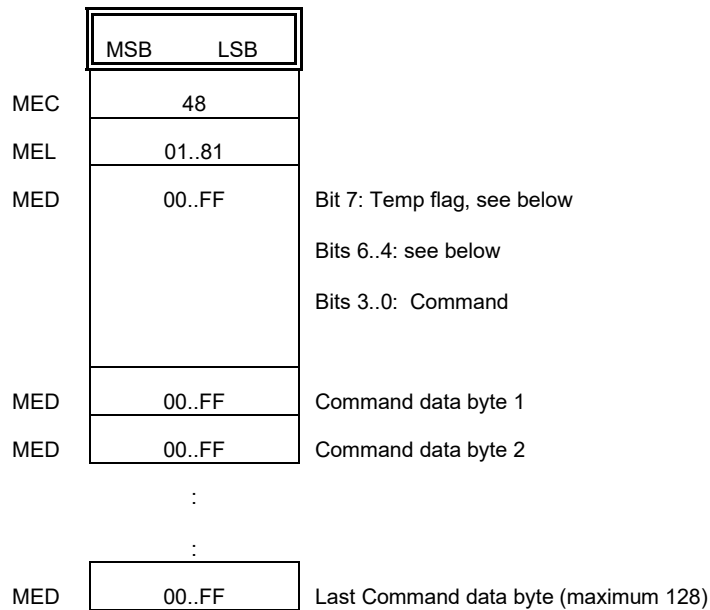

Coding of Dynamic Label command data is in accordance with ETSI EN 300 401 and ETSI TS 102 980 (Structure of the X-PAD data group for each DL segment):

- Bits 7** Temp flag: if set to "0" (e.g. with DL Plus tags command), the DL command is transmitted as long as no new data is available. Otherwise transmission is stopped immediately (after some repetition, if needed to guard against transmission errors)
- Bits 6 to 4** These bits shall be set as defined in ETSI TS 102 980
- Bits 3 to 0** Command as defined in ETSI TS 102 980 (bits 11..8) and ETSI EN 300 401.

EXAMPLE: <48><08><02><05><01><16><16><04><32><0A>

The DL command shown above is a DL Plus command (command = 2), specifically a "DL Plus tags" command.

This example is for the Dynamic Label message

<You are listening to "House of the Rising Sun" by Eric Burdon>

and the command gives the information to identify the tags "title" and "artist" by its position and length inside the Dynamic Label message.

Annex H (informative)

Example for defining the group sequence for data-stream 0 including ODA groups

When several ODAs are being used in an RDS data-stream, it can be very likely that the assignment groups (type 3A) have different repetition rates specified.

The example below shows how the data-stream shall be organized when 2 ODAs are used where ODA number 1 would need to have a high 3A assignment group rate as it should allow a receiver to fully autonomously tune and lock-on to stations which transmit this ODA. To speed up the scan function of the receiver, the 3A assignment group of this ODA shall be transmitted once every 2 s. The second ODA is not time critical and requires a rate of one 3A assignment group only every 10 s.

Assume ODA1 will be transmitted in group 9A and ODA2 will use 11A.

The other groups used are: 0A, 1A, 2A, 10A and 14A.

The transmission time for an RDS group is 87,6 ms, but to simplify the calculations in the example, 100 ms is chosen.

This means that the ODA1 assignment group type 3A shall appear once every 20 groups (20 × 100 ms = 2 s) and the ODA2 assignment group 3A only once every 100 groups and once every 10 s.

In symbolic group notation, the sequence would look like (20 groups/line):

```
(1) 0A 3A 0A 1A 2A 2A 10A 14A 14A 2A 2A 9A 9A 14A 14A 14A 1A 10A 0A 2A
(2) 0A 3A 2A 11A 2A 0A 0A 2A 14A 10A 2A 0A 0A 11A 11A 11A 1A 10A 0A 2A
(3) 0A 3A 2A 11A 2A 0A 0A 2A 14A 10A 2A 0A 0A 11A 11A 11A 1A 10A 0A 2A
(4) 0A 3A 2A 11A 2A 0A 0A 2A 14A 10A 2A 0A 0A 11A 11A 11A 1A 10A 0A 2A
(5) 1A 3A 2A 11A 2A 0A 0A 2A 14A 10A 2A 0A 0A 11A 11A 11A 1A 10A 0A 3A
```

This example shows that after every 20th group, one 3A group is inserted, and after every 100th group, another 3A group. The ODA application groups 9A and 11A are also inserted in the group sequence to enable the sending of the ODA1 and ODA2 data.

This required sequence is sent to the encoder using a UECP string coded with MEC 0x16:

```
MEC-DSN-MEL-DATA
<16><00><64><00><06><00><02><04><04><14><1C><1C><04><04><12><12><1C><1C>
...<06>
```

In MEC16, the group sequence is shown for all groups, but in this sequence, all 3A groups look the same, while they belong to different ODAs. Thus, in addition, MEC 0x41 is required, because the encoder has to be informed that the ODA1 in group 9A shall be signalled 5 times more often than the ODA2 in group type 11A so that receivers shall receive every 2 s a 3A group for the ODA1 and every 10 s a 3A group for the ODA2.

For the sequence shown above, the required 3A group type sequence is then:

9A 9A 9A 9A 9A 11A and using MEC 41, this yields the following UECP string:

```
MEC-DSN-MEL-DATA
<41><00><06><12><12><12><12><12><16>
```

Annex I (informative)

Example of how to send a logo with two different resolutions using RFT

I.1 Send files to the encoder

I.1.1 General

This example is intended to be used as a guideline to send files using the RFT protocol. It describes the steps to be taken to send the files to the encoder together with some instructions. When no additional data is required, these instructions are relatively simple and straightforward. For this logo application, an ODA AID of 0xFF7F is assumed and pipe 0 is used for the file data transport.

It is assumed that the files are called Lores.png (465 bytes) and Hires.jpg (3615 bytes) and one would like to use the default (automatic) CRC protection. Since file names are not supported in the definition of the RFT protocol, both files shall be given a file ID and a file version number. As this application is about a logo having two different resolutions, it makes sense to keep the file IDs identical and only use different file versions.

The result of this naming convention will thus be:

- Lores.png gets a File ID of 1 and a file version of 0;
- Hires.jpg gets a file ID of 1 and a file version of 1.

As far as the assignment goes, this is all information needed for the encoder to automatically generate variants 0 and 1 of the assignment group (see IEC 62106-2:2021, Annex C).

I.1.2 Alternative 1: using MECs 0x50 and 0x57

For the RFT protocol the channel/pipe assignment is done with MEC 0x50.

	MSB	LSB	
MEC	50		
MEL	03		Message length
MED	00		Channel number
MED	FF		Block 2 (AID – MSB)
MED	7F		Block 2 (AID – LSB)

For this application, the AID is 0xFF7F and the channel/pipe to be assigned is 0.

MEC 50 is then coded as follows: <50><03><00><FF><7F>

For the RFT protocol, the file data transfer is done with MEC 0x57.

For each UECP frame using MEC 0x57, a maximum of 244 bytes of file data can be transferred. As in MEC0x57, also the total amount of frames needs to be entered, first the total number of frames needs to be calculated. The total number of frames is file size / 244. If the result of this division is not a whole number, the total number of frames is increased by 1.

A series of MEC 0x57 shall now be sent to the encoder. The first one to be sent to the RDS2 encoder is shown below:

MEC	57	
MEL	FD	Length = 253
MED	FF	AID
MED	7F	
MED	06	Add file ID 1 in the list for that AID + Configuration
MED	01	File version is 0, CRC is required
MED	04	AS group spacing (20 groups)
MED	E0..EF	CRC mode is "auto" (IEC 62106-2:2021, Annex C) + no variants + MSN* of the total number of frames to be received by the encoder
MED	00..FF	LSB of total number of frames to be received by the encoder
MED	00	Transmission of frame number 1
MED	01	
MED	89	1 st File data byte
MED	50	2 nd File data byte
...
MED	1C	243 rd File data byte
MED	F2	244 th File data byte

(*): MSN = Most Significant Nibble (4 bits) of the total number of frames (0xFFF)

The next frame will have frame number 2 and will start with data byte number 245. When the file size division does not yield a whole number, the last frame will have a shorter length and the MEL will be smaller than 253. When the last frame has been sent, the encoder has all information of the file and is ready to start transmitting RFT groups, where variants 0 and 1 are automatically generated by the encoder.

Sending the next file to the encoder is fully identical to the method described above, with only a different version and a different total number of frames and, of course, different file data bytes.

Next to the real file data and its associated information, a number of other parameters shall be set to influence the way the file is sent using RDS2 groups. These are stream numbers to be used, repetition rates and such, which is dealt with in Clauses I.2 and I.3.

I.1.3 Alternative 2: using MECs 0x51 and 0x55

For the RFT protocol the channel/ pipe assignment is done with MEC 0x51.

	MSB	LSB	
MEC	51		
MEL	06		Message length
MED	05		AS group Spacing (5x5=25 groups)
MED	80		automatic CRC is required Channel/Pipe = 0
MED	42		RFT assignment and cyclic transmission
MED	FF		Block 2 (AID- MSB)
MED	7F		Block 2 (AID – LSB)

For this application the AID is 0xFF7F and the channel/pipe to be assigned is 0. The channel/pipe assignment group is file-related, so bit 6 of the configuration byte is set to 1. This assignment does not contain additional data. For the AS group, spacing is set to 25 groups.

The coding of MEC 0x51 will thus be as follows:

<51><06><05><00><42><FF><7F>

This will repeat the AS group (AID FF7F on channel/pipe 0) every 25 groups (2,2 s).

For this Alternative 2 and for the RFT protocol, the file data transfer is done with MEC 0x55.

In this example, variant 0 will be created based on the data in MEC0x55.

For each UECP frame using MEC 0x55, a maximum of 246 bytes of file data can be transferred. As in MEC0x55, also the total amount of frames needs to be entered; first, the total number of frames needs to be calculated. The total number of frames is file size / 246. If the result of this division is not a whole number, the total number of frames is increased by 1.

A series of MEC 0x55 shall now be sent to the encoder. The first one to be sent to the RDS2 encoder is shown below:

Format:

	MSB	LSB	
MEC	55		
MEL	FD		MEC length = 253
MED	FF		AID MSB
MED	7F		AID LSB
MED	01		Repeat style default (0) and File ID = 1
MED	00		Repeat count default (0), File Version (0) MSB frames=0
MED	02		Total number of frames = 2 (LoRes.png = 465 bytes)
MED	80		CRC flag set, MSB frame number = 0 (first frame)
MED	01		First frame
MED	00..FF		First byte of the file
MED	00..FF		Second byte of the file
MED	:		
MED	00..FF		Last byte of the file

The next frame will have frame number 2 and will start with data byte number 247. When the file size division does not yield a whole number, the last frame will have a shorter length and the MEL will be smaller than 253. When the last frame has been sent, the encoder has all information of the file and is ready to start transmitting RFT groups, where variants 0 and 1 are automatically generated by the encoder.

Sending the next file to the encoder is fully identical to the method described above, with only a different version and a different total number of frames and, of course, different file data bytes.

Next to the real file data and its associated information, a number of other parameters shall be set to influence the way the file is sent using RDS2 groups. These are stream numbers to be used, repetition rates and such, which is dealt with in Clauses I.2 and I.3.

I.2 Data-stream number setting

This is a mandatory setting which is fully controlled by the broadcaster or transmission operator. In this example, data-stream 3 is chosen to carry the logo data in pipe 0 and no other channels or groups will be present in data-stream 3.

To set this configuration, MEC0x61 is used as follows:

MEC	61	
DSN	00	Current DSN
MEL	02	Length
MED	03	Group sequence is for data-stream 3
MED	20	Pipe 0

I.3 File sequence setting

As multiple files are used in this example, the transmission sequence of these files may be set, which allows giving preference to, in this case, one of the two files; for instance, to transmit the Lores.png file twice as often as the Hires.jpg file.

To accomplish this setup, MEC 0x59 is sent:

MEC	59	
MEL	09	Length
MED	03	Number of the file identifiers in the list
MED	FF	AID for logo transmission
MED	7F	
MED	01	File ID 1
MED	00	File version 0
MED	01	File ID 1
MED	00	File version 0
MED	01	File ID 1
MED	01	File version 1

Before the actual transmission starts, all settings are to be sent.

Bibliography

- [1] RDS Forum Technical Specification SPB 490, version 7.05, RDS Universal Encoder Communication Protocol
 - [2] EBU (1984): *Specifications of the radio data system RDS for VHF/FM sound broadcasting*. Doc. Tech 3244 and Supplements 1 to 4. European Broadcasting Union
 - [3] WRIGHT, S. *The Broadcaster's Guide to RDS*
Published by Focal Press, Boston, Oxford, Johannesburg, Melbourne, New Delhi, Singapore, 1997, ISBN 0-240-80278-0
 - [4] KOPITZ, D. and MARKS, B., *RDS – The Radio Data System*
Published by Artech House Publishers, Boston and London, 1999, ISBN 0-89006-744-9
 - [5] EN 50067, *Specification of the radio data system (RDS for VHF/FM sound broadcasting in the frequency range from 87,5 to 108,0 MHz*
 - [6] US NRSC-4-B, *National Radio Systems Committee – NRSC-4-A: United States RBDS standard*, 2011
 - [7] IEC 62106-3:2018, *Radio data system (RDS) – VHF/FM sound broadcasting in the frequency range from 64,0 MHz to 108,0 MHz – Part 3: Usage and registration of Open Data Applications (ODAs)*
 - [8] ISO TS 14819 – all parts, *Traffic and Traveller Information (TTI) – TTI Messages via Traffic Message*
 - [9] ETSI EN 300 468, *Specification for Service Information (SI) in DVB systems*
 - [10] ETSI TR 101 154, *Specification for the use of Video and Audio Coding in Broadcasting Applications based on MPEG-2 Transport Stream*
 - [11] ETSI TS 101 211, *Digital Video Broadcasting (DVB) – Guideline on implementation and usage of Service Information (SI)*
-

INTERNATIONAL
ELECTROTECHNICAL
COMMISSION

3, rue de Varembé
PO Box 131
CH-1211 Geneva 20
Switzerland

Tel: + 41 22 919 02 11
info@iec.ch
www.iec.ch